

## SSMA STRAIGHT CRIMP/CRIMP PLUG 36-005-H3-AD

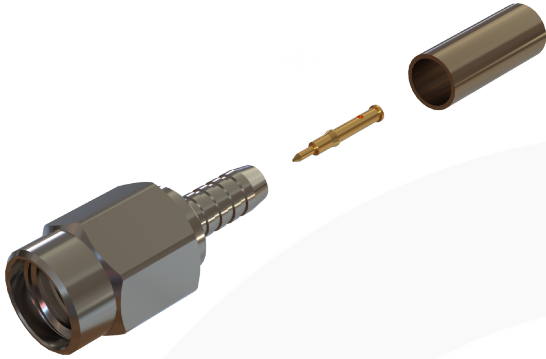

images for illustration purposes only

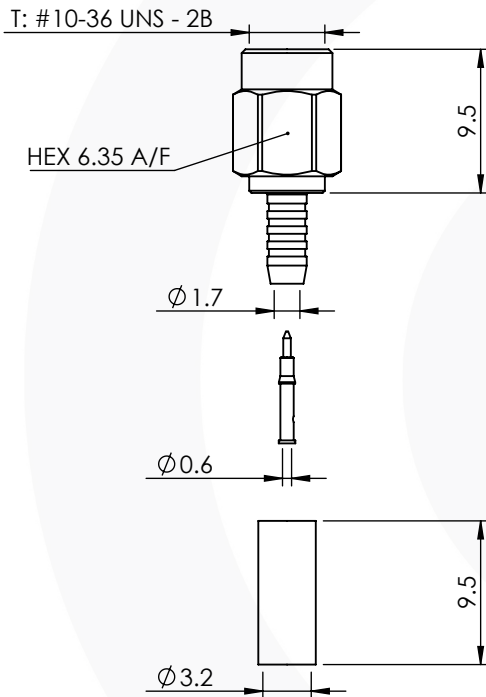

### Suitable for Cables:

(AD) RG316, RG174, RG188, LMR100, WBC100, URM95, KX3, KX22

### Stripping Dimensions

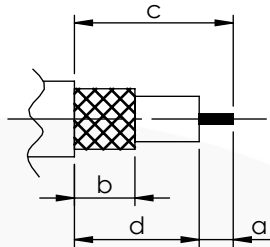

a = 2.0 mm  
b = 7.0 mm  
c = 10.0 mm  
d = 8.0 mm

\* CUT FOIL TO DIM. "b"

### Assembly Procedure:

#### Tooling

Centre Contact: Indent or Solder      Tool No: DMC AFM8

Crimp Sleeve: Hex 3.25mm A/F      Tool No: 336J

Alignment Tool: Not Applicable      Extraction: Not Applicable

### Environmental Specification

Operating Temp: -55 to +155 Deg C.

IP Rating (Mated): IP 50

### Electrical Specification

Impedance: 50 Ohm

Frequency: 0-18 GHz

Dielectric W/V: 750 Veff

Insulation res: 5000 M-Ohm

### Mechanical Specification

Contact Retention: 22 N min

Cable Retention: 60 N min

Mating cycles: 500

Weight: 1.91 g

### Connector Interface

image for illustration purposes only

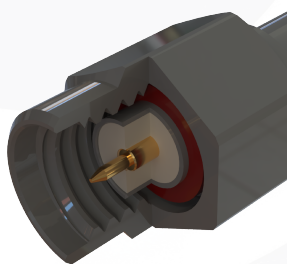

7	RETAINING RING	BERYLLIUM COPPER	NICKEL
6	COUPLING NUT	STAINLESS STEEL	PASSIVATED
5	GASKET	SILICONE	N/A
4	CRIMP SLEEVE	BRASS	NICKEL
3	INSULATOR	PTFE	N/A
2	CENTRE CONTACT	BRASS	GOLD
1	BODY	STAINLESS STEEL	PASSIVATED
ITEM	DESCRIPTION	MATERIAL	PLATING

<b>A4</b>	SHEET 1 OF 1	DIMENSIONS ARE IN MILLIMETRES		
REVISION :	A00	NAME	SIGNATURE	DATE
ISSUE :	3	DRAWN	G.E.	15/12/2025
		CHK'D	P.S.	15/12/2025
		APPV'D		
6-8 COLNE ROAD, TWICKENHAM, MIDDLESEX. TW1 4JR				
THE INFORMATION IS GIVEN AS AN INDICATION ONLY AND IS SUBJECT TO CHANGE WITHOUT NOTICE. IN THE CONTINUAL GOAL TO IMPROVE OUR PRODUCTS, WE RESERVE THE RIGHT TO MAKE ANY MODIFICATIONS NECESSARY WITHOUT PRIOR NOTICE.				