

## BNC RIGHT ANGLED BULKHEAD PCB JACK 2-WAY

### 92-10-468-B3

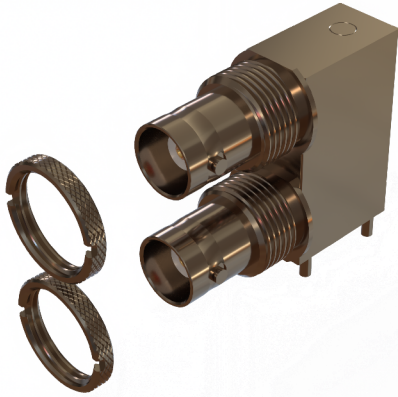

images for illustration purposes only

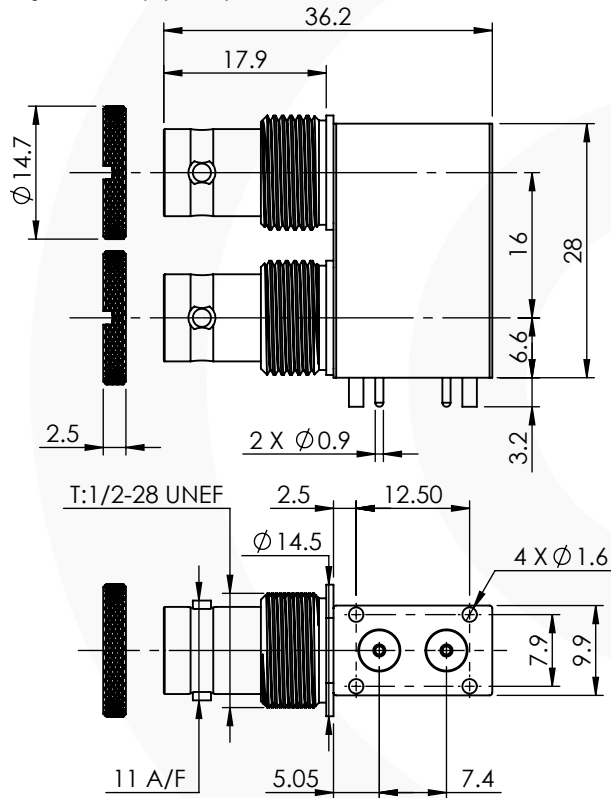

### Recommended Mounting:

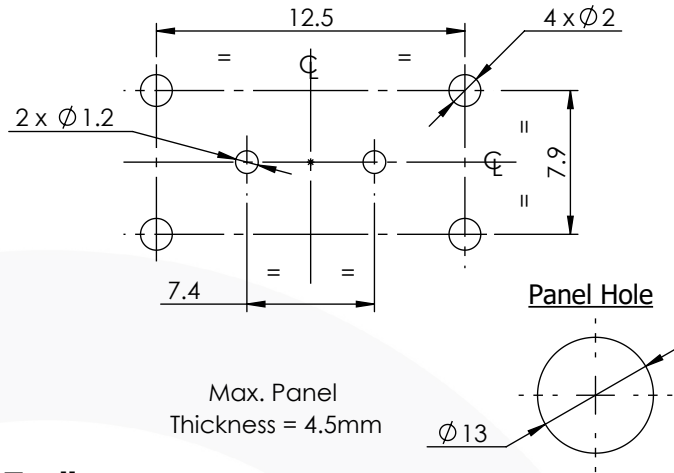

Max. Panel Thickness = 4.5mm

### Tooling

- Centre Contact: Solder      Tool No: Solder
- Crimp Sleeve: Not Applicable      Tool No: Not Applicable
- Alignment Tool: Not Applicable      Extraction: Not Applicable

### Environmental Specification

Operating Temp: -55 to +155 Deg C.  
IP Rating (Mated): IP 40

### Electrical Specification

Impedance: 50 Ohm  
Frequency: 0-3 GHz  
Dielectric W/V: 1500 Veff  
Insulation res: 5000 M-Ohm

### Mechanical Specification

Contact Retention: 15 N min  
Cable Retention: Not Applicable  
Mating cycles: 250  
Weight: 53.30 g

### Connector Interface

image for illustration purposes only

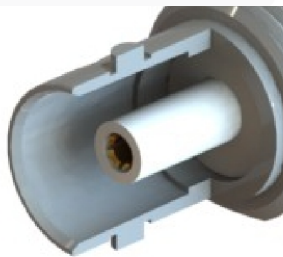

4	KNURLED NUTS	BRASS	NICKEL
3	INSULATORS	PTFE	N/A
2	CENTRE CONTACT	PHOSHOR BRONZE	GOLD
1	BODIES	BRASS	NICKEL
ITEM	DESCRIPTION	MATERIAL	PLATING

<b>A4</b>	SHEET 1 OF 1	DIMENSIONS ARE IN MILLIMETRES		
REVISION :	A00	NAME	SIGNATURE	DATE
ISSUE :	1	DRAWN	G.E.	02/10/2024
		CHK'D	P.S.	02/10/2024
		APPV'D		
6-8 COLNE ROAD, TWICKENHAM, MIDDLESEX. TW1 4JR				
THE INFORMATION IS GIVEN AS AN INDICATION ONLY AND IS SUBJECT TO CHANGE WITHOUT NOTICE. IN THE CONTINUAL GOAL TO IMPROVE OUR PRODUCTS, WE RESERVE THE RIGHT TO MAKE ANY MODIFICATIONS NECESSARY WITHOUT PRIOR NOTICE.				