

## SMA STRAIGHT SOLDER / CRIMP PLUG 30-008-DS3-AH

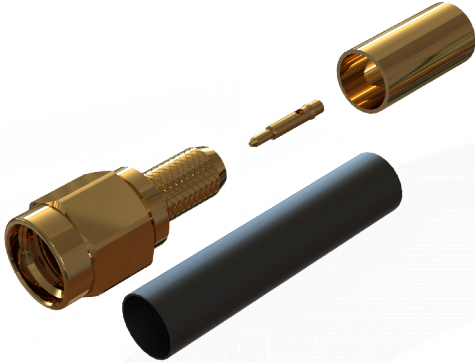

images for illustration purposes only

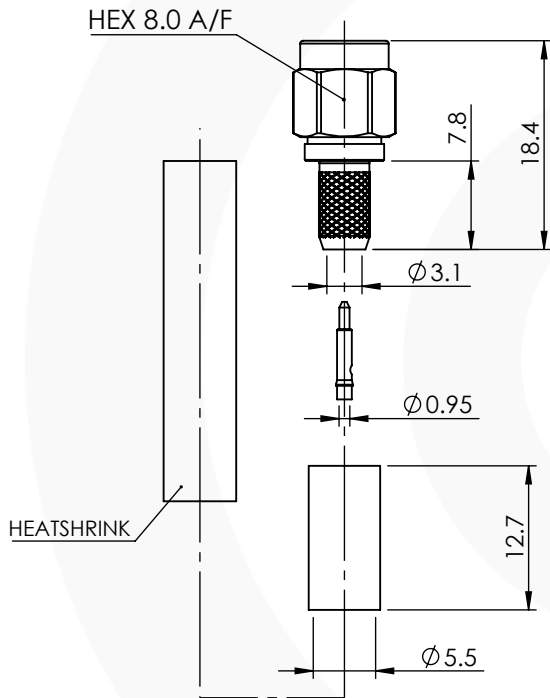

### Suitable for Cables:

(AH) RG58, RG141, LMR195, URM43, URM76, WBC195, PSF 1/6, KX15, KX23

### Stripping Dimensions

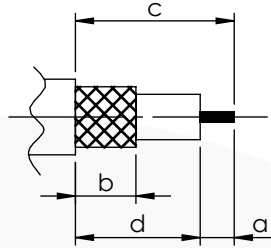

a = 3.0 mm  
b = 8.0 mm  
c = 12.5 mm  
d = 9.5 mm

\* CUT FOIL TO DIM. "b"

### Assembly Procedure: AP004

### Tooling

Centre Contact: Solder Tool No: Not Applicable

Crimp Sleeve: Hex 5.41mm A/F Tool No: 336A

Alignment Tool: Not Applicable Extraction: Not Applicable

### Environmental Specification

Operating Temp: -55 to +155 Deg C.

IP Rating (Mated): IP 64

### Electrical Specification

Impedance: 50 Ohm

Frequency: 0-12 GHz

Dielectric W/V: 750 Veff

Insulation res: 5000 M-Ohm

### Mechanical Specification

Contact Retention: 10 N min

Cable Retention: 150 N min

Mating cycles: 250

Weight: 4.01 g

### Connector Interface

image for illustration purposes only

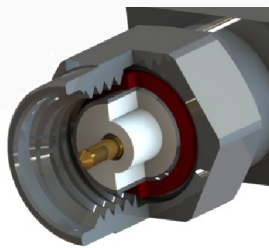

8	HEATSHRINK	POLYOLEFIN	N/A
7	INNER RETAINING RING	STAINLESS STEEL	NICKEL
6	COUPLING NUT	STAINLESS STEEL	GOLD
5	GASKET	SILICONE	N/A
4	CRIMP SLEEVE	BRASS	GOLD
3	INSULATOR	PTFE	N/A
2	CENTRE CONTACT	BRASS	GOLD
1	BODY	STAINLESS STEEL	GOLD
ITEM	DESCRIPTION	MATERIAL	PLATING

<b>A4</b>	SHEET 1 OF 1	DIMENSIONS ARE IN MILLIMETRES		
REVISION :	A00	NAME	SIGNATURE	DATE
DRAWN		G.E.		02/05/2024
ISSUE :	2	CHK'D	P.S.	02/05/2024
APP'V'D				
6-8 COLNE ROAD, TWICKENHAM, MIDDLESEX. TW1 4JR THE INFORMATION IS GIVEN AS AN INDICATION ONLY AND IS SUBJECT TO CHANGE WITHOUT NOTICE. IN THE CONTINUAL GOAL TO IMPROVE OUR PRODUCTS, WE RESERVE THE RIGHT TO MAKE ANY MODIFICATIONS NECESSARY WITHOUT PRIOR NOTICE.				