

N JACK TO N JACK HERMETICALLY SEALED BULKHEAD ADAPTOR

25-560-P3

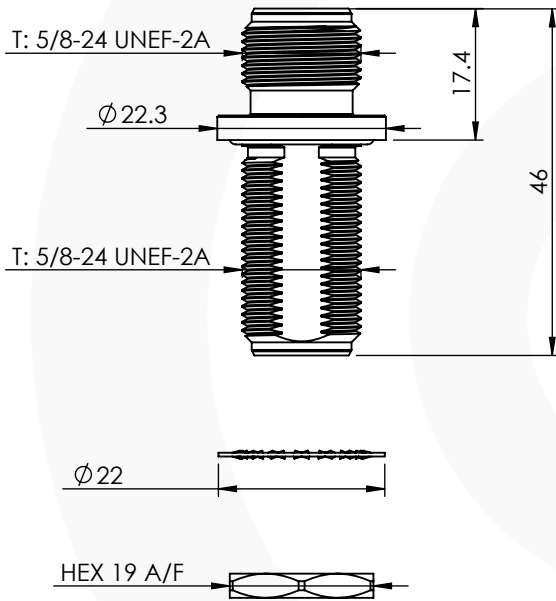

images for illustration purposes only



Environmental Specification

Operating Temp: -55 to +155 Deg C.

IP Rating (Mated): IP 68 (75m - 24 HR.)

Electrical Specification

Impedance: 50 Ohm

Frequency: 0-12 GHz

Dielectric W/V: 1500 Veff

Insulation res: 5000 M-Ohm

Mechanical Specification

Contact Retention: 27 N min

Cable Retention: Not Applicable

Mating cycles: 500

Weight: 56.53 g

Connector Interface

image for illustration purposes only

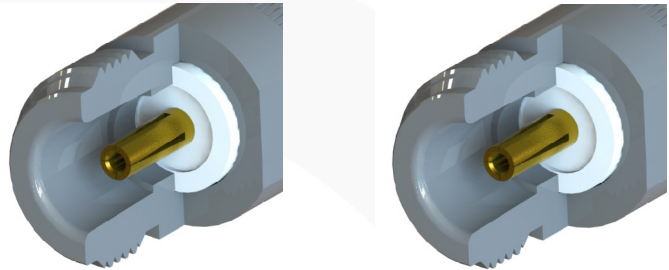

Recommended Mounting

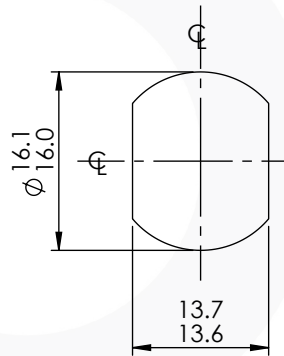

Max Panel Thickness:
13.0 mm

Performance

-33.37 dB @ 3.0 GHz

-13.59 dB @ 6.0 GHz

-25.18 dB @ 9.0 GHz

-17.97 dB @ 12.0GHz

Return Loss Graph

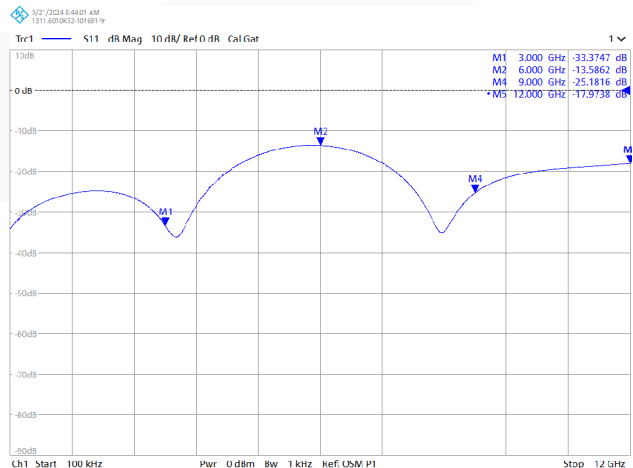

7	HERMETIC SEAL	GLASS	N/A
6	WASHERS	SK5	WHITE BRONZE
5	NUT	BRASS	WHITE BRONZE
4	GASKETS	SILICONE	N/A
3	INSULATOR	PTFE	N/A
2	CENTRE CONTACTS	PHOSPHOR BRONZE	GOLD
1	BODIES	BRASS	WHITE BRONZE
ITEM	DESCRIPTION	MATERIAL	PLATING

A4	SHEET 1 OF 1	DIMENSIONS ARE IN MILLIMETRES		
REVISION :	A00	NAME	SIGNATURE	DATE
ISSUE :	2	DRAWN	G.E.	17/01/2024
		CHK'D	P.S.	17/01/2024
		APPV'D		
6-8 COLNE ROAD, TWICKENHAM, MIDDLESEX. TW1 4JR				
THE INFORMATION IS GIVEN AS AN INDICATION ONLY AND IS SUBJECT TO CHANGE WITHOUT NOTICE. IN THE CONTINUAL GOAL TO IMPROVE OUR PRODUCTS, WE RESERVE THE RIGHT TO MAKE ANY MODIFICATIONS NECESSARY WITHOUT PRIOR NOTICE.				