

BNC STRAIGHT CRIMP / CRIMP PLUG

10-005-B126-FR

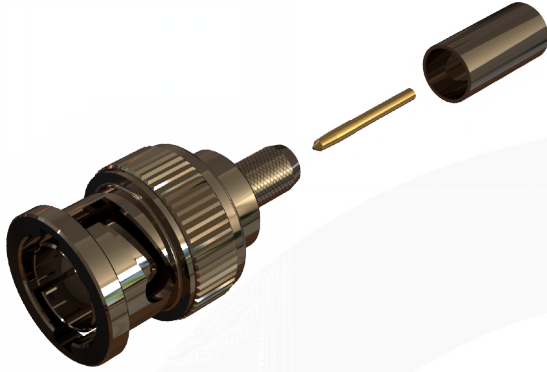

images for illustration purposes only

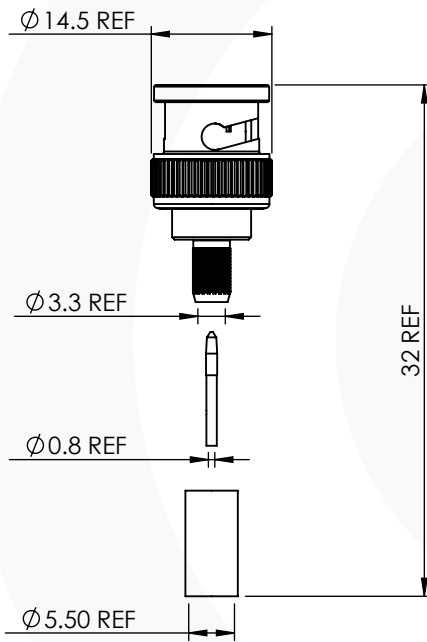

Suitable for Cables:

(FR) SDV-UHD-LFH, Draka Ultra HD Pro 50 UHD

Stripping Dimensions

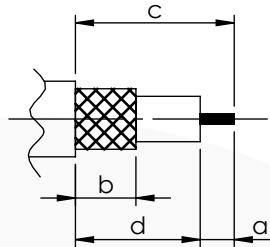

a = 4.0 mm
b = 8.0 mm
c = 16.0 mm
d = 12.0 mm

* CUT FOIL TO DIM. "b"

Assembly Procedure: AP001

Tooling

Centre Contact: SQ 0.95mm A/F Tool No: 96-HTS-75A

Crimp Sleeve: HEX 5.41mm A/F Tool No: 96-HTS-75A

Alignment Tool: Not Applicable Extraction: 96-2208

Environmental Specification

Operating Temp: -55 to +155 Deg C.

IP Rating (Mated): IP 64

Electrical Specification

Impedance: 75 Ohm

Frequency: 0 - 18 GHz

Dielectric W/V: 1500 Veff

Insulation res: 5000 M-Ohm

Mechanical Specification

Contact Retention: 10 N min

Cable Retention: 100 N min

Mating cycles: 500

Weight: 10.08 g

Connector Interface

image for illustration purposes only

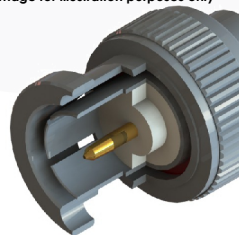

Performance

-29.97 dB @ 3.0 GHz

-26.59 dB @ 6.0 GHz

-24.32 dB @ 9.0 GHz

-19.85 dB @ 12.0 GHz

Return Loss Graph

ITEM	DESCRIPTION	MATERIAL	PLATING
7	WASHER	SK5	NICKEL
6	BAYONET CAP	ZINC	NICKEL
5	CRIMP SLEEVE	BRASS	NICKEL
4	GASKET	SILICONE	N/A
3	CENTRE CONTACT	BRASS	GOLD
2	INSULATOR	PTFE	N/A
1	BODY	BRASS	NICKEL

A4 SHEET 1 OF 1		DIMENSIONS ARE IN MILLIMETRES		
REVISION :	A00	NAME	SIGNATURE	DATE
ISSUE :	1	DRAWN	G.E.	18/12/2023
		CHK'D	G.E.	18/12/2023
		APPV'D		
6-8 COLNE ROAD, TWICKENHAM, MIDDLESEX. TW1 4JR				
THE INFORMATION IS GIVEN AS AN INDICATION ONLY AND IS SUBJECT TO CHANGE WITHOUT NOTICE. IN THE CONTINUAL GOAL TO IMPROVE OUR PRODUCTS, WE RESERVE THE RIGHT TO MAKE ANY MODIFICATIONS NECESSARY WITHOUT PRIOR NOTICE.				