

N TYPE 4 HOLE FLANGE CRIMP/CRIMP JACK

25-278-B3-DB

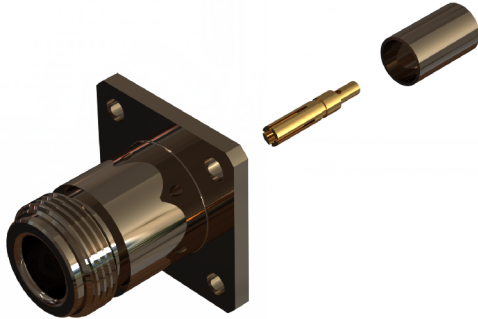

images for illustration purposes only

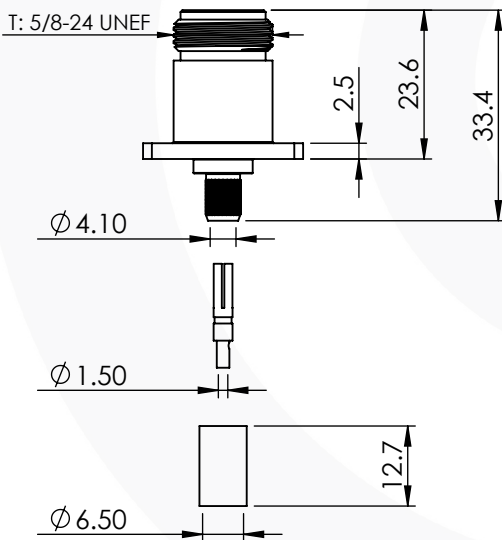
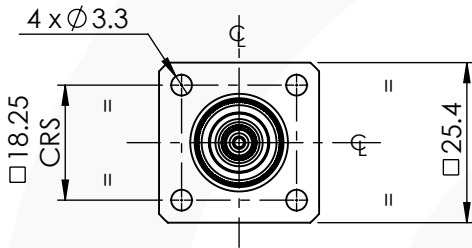

Suitable for Cables:

(DB) LMR240

Stripping Dimensions

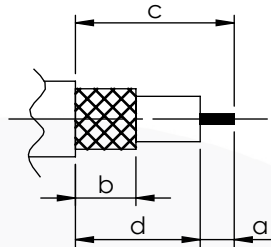

- a = 4.0 mm
- b = 8.5 mm
- c = 17.5 mm
- d = 13.5 mm

Assembly Procedure: AP001

Tooling

Centre Contact: Hex 1.72mm A/F Tool No: 336A

Crimp Sleeve: HEX 6.48mm A/F Tool No: 336A

Alignment Tool: Not Applicable Extraction: Not Applicable

Environmental Specification

Operating Temp: -55 to +155 Deg C.

IP Rating (Mated): IP 67

Electrical Specification

Impedance: 50 Ohm

Frequency: 0-10 GHz

Dielectric W/V: 1500 Veff

Insulation res: 5000 M-Ohm

Mechanical Specification

Contact Retention: 10 N min

Cable Retention: 150 N min

Mating cycles: 500

Weight: 40.06 g

Connector Interface

image for illustration purposes only

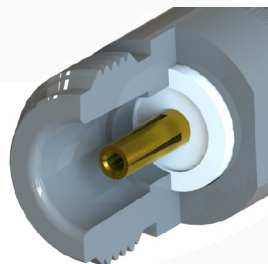

Recommended Mounting

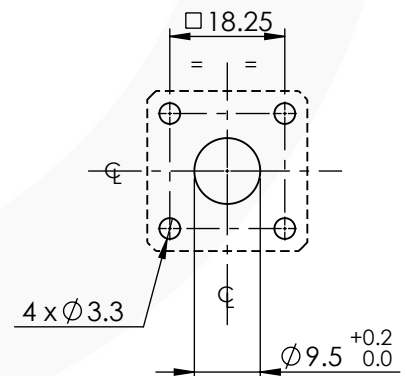

ITEM	DESCRIPTION	MATERIAL	PLATING
6	CRIMP TUBE	BRASS	NICKEL
5	CENTRE CONTACT	PHOSPHOR BRONZE	GOLD
4	REAR BODY	BRASS	NICKEL
2	INSULATOR	PTFE	N/A
1	BODY	BRASS	NICKEL

A4	SHEET 1 OF 1	DIMENSIONS ARE IN MILLIMETRES		
REVISION :	A00	NAME	SIGNATURE	DATE
ISSUE :	1	DRAWN	G.E.	25/09/2023
		CHK'D	P.S.	25/09/2023
		APPV'D		
6-8 COLNE ROAD, TWICKENHAM, MIDDLESEX. TW1 4JR				
THE INFORMATION IS GIVEN AS AN INDICATION ONLY AND IS SUBJECT TO CHANGE WITHOUT NOTICE. IN THE CONTINUAL GOAL TO IMPROVE OUR PRODUCTS, WE RESERVE THE RIGHT TO MAKE ANY MODIFICATIONS NECESSARY WITHOUT PRIOR NOTICE.				