

TNC STRAIGHT FRONT MOUNT BULKHEAD SOLDER BUCKET JACK

13-388-2-B3-RD

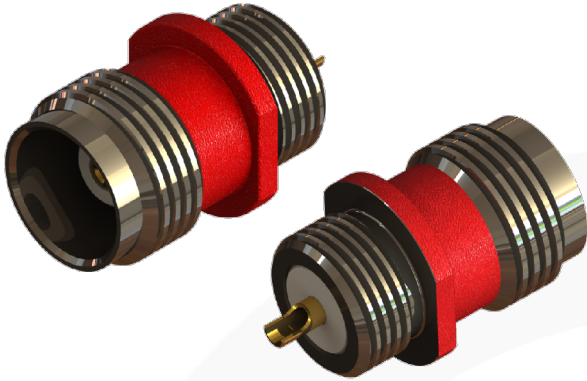

images for illustration purposes only

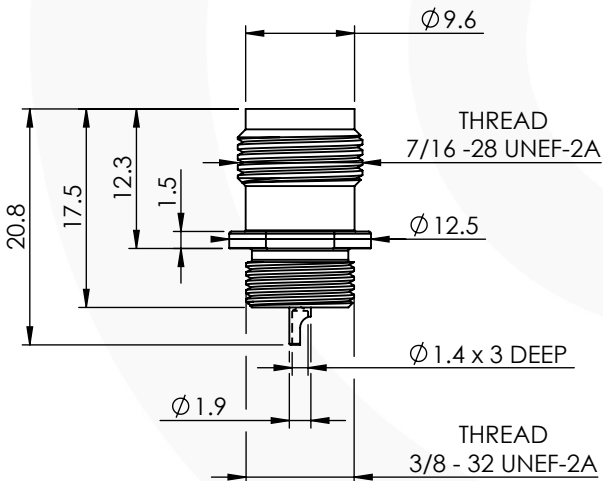
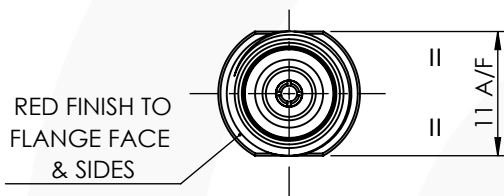

Tooling

Centre Contact: Solder

Tool No: Solder

Crimp Sleeve: Not Applicable

Tool No: Not Applicable

Alignment Tool: Not Applicable

Extraction: Not Applicable

Environmental Specification

Operating Temp: -65 to +165 Deg C.

IP Rating (Mated): IP 40

Electrical Specification

Impedance: 50 Ohm

Frequency: 0-11 GHz

Dielectric W/V: 1500 Veff

Insulation res: 5000 M-Ohm

Mechanical Specification

Contact Retention: 10 N min

Cable Retention: Not Applicable

Mating cycles: 500

Weight: 6.01 g

Connector Interface

image for illustration purposes only



4	RETAINER	BRASS	NICKEL
3	INSULATOR	PTFE	N/A
2	CENTRE CONTACT	BERYLLIUM COPPER	GOLD
1	BODY	BRASS	NICKEL
ITEM	DESCRIPTION	MATERIAL	PLATING

A4	SHEET 1 OF 1	DIMENSIONS ARE IN MILLIMETRES		
REVISION :	A00	NAME	SIGNATURE	DATE
ISSUE :	1	DRAWN	G.E.	11/07/2023
		CHK'D	P.S.	11/07/2023
		APPV'D		
<p>6-8 COLNE ROAD, TWICKENHAM, MIDDLESEX. TW1 4JR</p> <p>THE INFORMATION IS GIVEN AS AN INDICATION ONLY AND IS SUBJECT TO CHANGE WITHOUT NOTICE. IN THE CONTINUAL GOAL TO IMPROVE OUR PRODUCTS, WE RESERVE THE RIGHT TO MAKE ANY MODIFICATIONS NECESSARY WITHOUT PRIOR NOTICE.</p>				