

## SMA STRAIGHT BULKHEAD CRIMP/CRIMP JACK

### 30-254-D3-AK

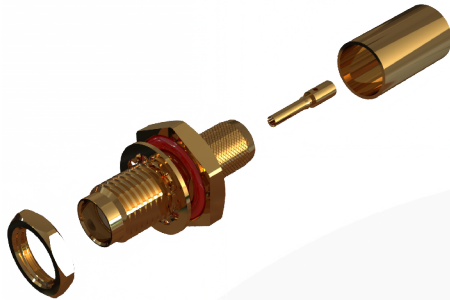

images for illustration purposes only

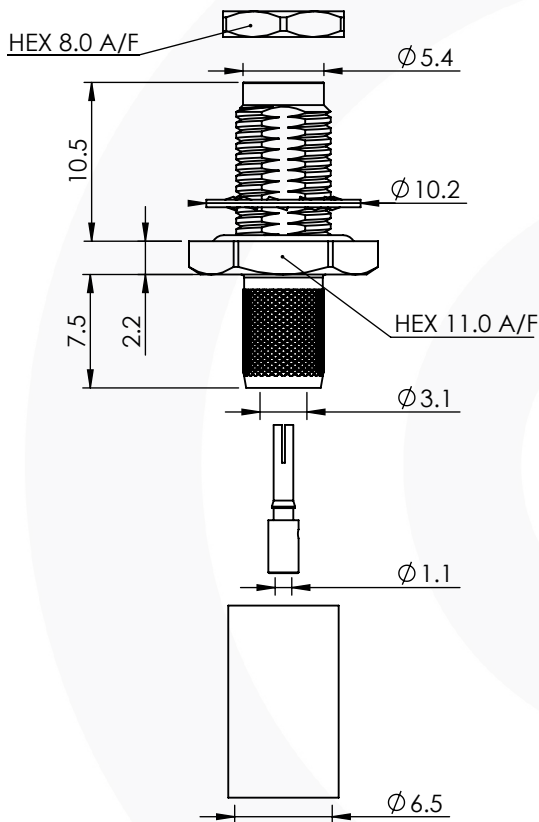

### Suitable for Cables:

(AK) RG223

### Stripping Dimensions

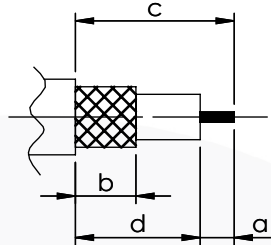

a = 3.0 mm  
b = 8.0 mm  
c = 12.0 mm  
d = 9.0 mm

### Assembly Procedure: AP001

### Tooling

Centre Contact: Hex 1.72mm A/F Tool No: 336A

Crimp Sleeve: HEX 6.48mm A/F Tool No: 336A

### Environmental Specification

Operating Temp: -55 to +155 Deg C.

IP Rating (Mated): IP 54

### Electrical Specification

Impedance: 50 Ohm

Frequency: 0-12 GHz

Dielectric W/V: 750 Veff

Insulation res: 5000 M-Ohm

### Mechanical Specification

Contact Retention: 27 N min

Cable Retention: 220 N min

Mating cycles: 500

Weight: 5.08 g

### Connector Interface

image for illustration purposes only

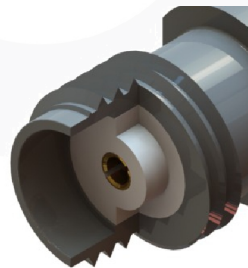

### Recommended Mounting Hole

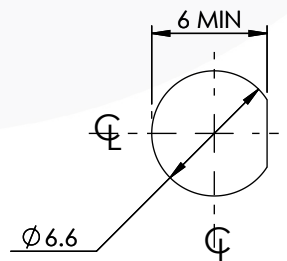

RECOMMENDED TORQUE FOR PANEL NUT : 150Ncm  
MAXIMUM PANEL THICKNESS : 6mm

7	WASHER	BeCu	GOLD
6	NUT	BRASS	GOLD
5	GASKET	SILICONE	N/A
4	CRIMP SLEEVE	BRASS	GOLD
3	INSULATOR	PTFE	N/A
2	CENTRE CONTACT	BeCu	GOLD
1	BODY	BRASS	GOLD
ITEM	DESCRIPTION	MATERIAL	PLATING

<b>A4</b>	SHEET 1 OF 1		DIMENSIONS ARE IN MILLIMETRES		
REVISION :	A01		NAME	SIGNATURE	DATE
DRAWN			G.E.		12/10/2023
ISSUE :	1		CHK'D	P.S.	12/10/2023
			APPV'D		
<p><b>6-8 COLNE ROAD, TWICKENHAM, MIDDLESEX. TW1 4JR</b></p> <p>THE INFORMATION IS GIVEN AS AN INDICATION ONLY AND IS SUBJECT TO CHANGE WITHOUT NOTICE. IN THE CONTINUAL GOAL TO IMPROVE OUR PRODUCTS, WE RESERVE THE RIGHT TO MAKE ANY MODIFICATIONS NECESSARY WITHOUT PRIOR NOTICE.</p>					