

## N TYPE 4 HOLE FLANGE CRIMP JACK 25-278-B3-AK

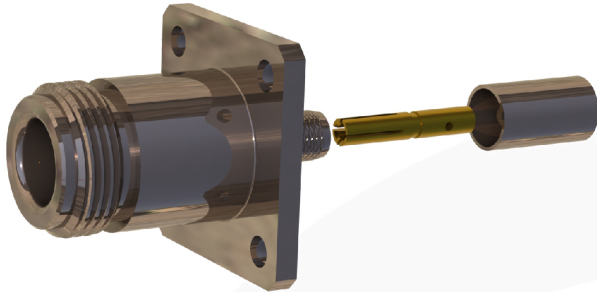

### Suitable for Cables:

(AK) RG223

### Stripping Dimensions

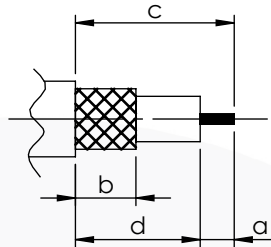

- a = 4.0 mm
- b = 8.0 mm
- c = 17.0 mm
- d = 13.0 mm

### Assembly Procedure: AP001

### Tooling

Centre Contact: Hex 2.54mm A/F Tool No: 336G

Crimp Sleeve: Hex 6.50mm A/F Tool No: 336G

Alignment Tool: Not Applicable Extraction: Not Applicable

### Environmental Specification

Operating Temp: -55 to +155 Deg C.

IP Rating (Mated): IP 67

### Electrical Specification

Impedance: 50 Ohm

Frequency: 0-10 GHz

Dielectric W/V: 1500 Veff

Insulation res: 5000 M-Ohm

### Mechanical Specification

Contact Retention: 10 N min

Cable Retention: 150 N min

Mating cycles: 500

Weight: 39.16 g

### Connector Interface

image for illustration purposes only

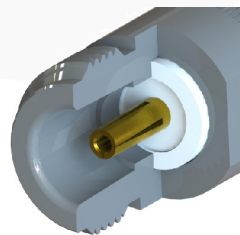

images for illustration purposes only

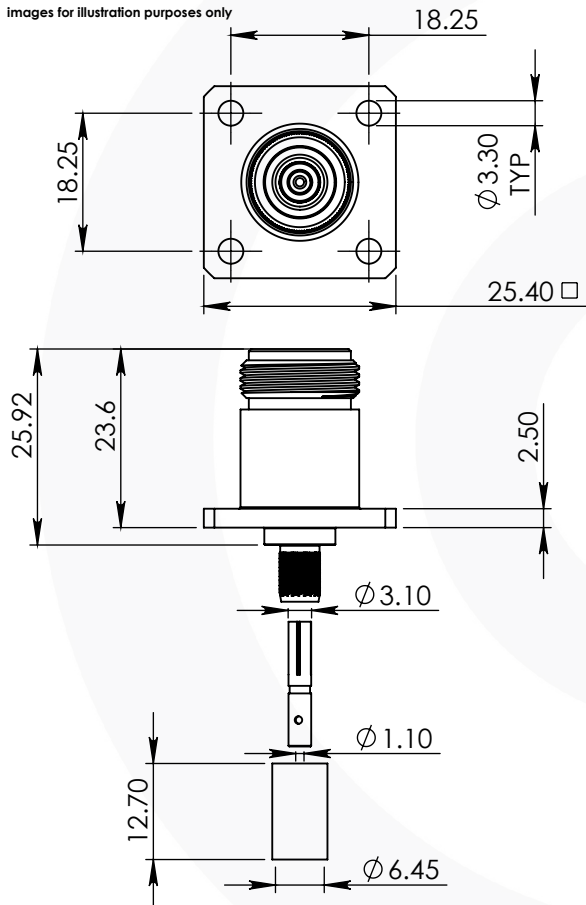

6	CRIMP TUBE	BRASS	NICKEL
5	CENTRE CONTACT	PHOSPHOR BRONZE	GOLD
4	REAR BODY	BRASS	NICKEL
2	INSULATOR	PTFE	N/A
1	BODY	BRASS	NICKEL
ITEM	DESCRIPTION	MATERIAL	PLATING

<b>A4</b>		DIMENSIONS ARE IN MILLIMETRES		
REVISION : B01		NAME	SIGNATURE	DATE
ISSUE : 1		DRAWN IG		12/03/2018
6-8 COLNE ROAD, TWICKENHAM, MIDDLESEX. TW1 4JR		CHK'D GE		13/03/2018
		APPV'D		
THE INFORMATION IS GIVEN AS AN INDICATION ONLY AND IS SUBJECT TO CHANGE WITHOUT NOTICE. IN THE CONTINUAL GOAL TO IMPROVE OUR PRODUCTS, WE RESERVE THE RIGHT TO MAKE ANY MODIFICATIONS NECESSARY WITHOUT PRIOR NOTICE.				

### FLANGE DETAILS

