

SMA TO SMB HERMETICALLY SEALED BULKHEAD ADAPTOR

74-3032-1-541

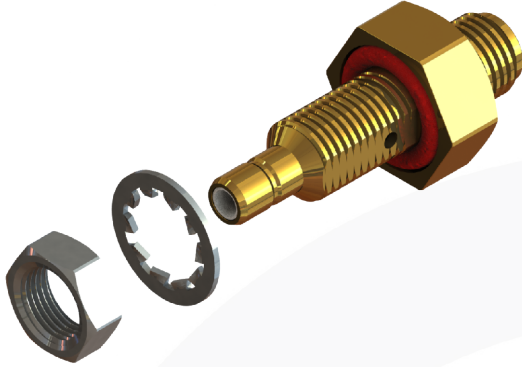

images for illustration purposes only

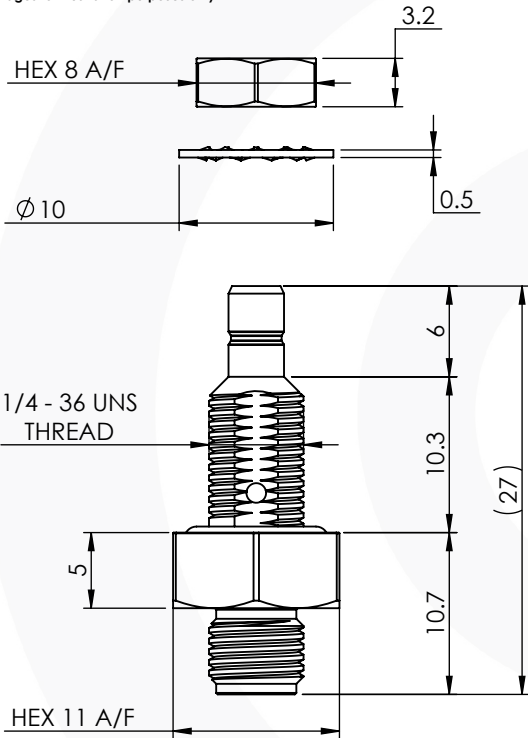

Recommended Mounting Hole

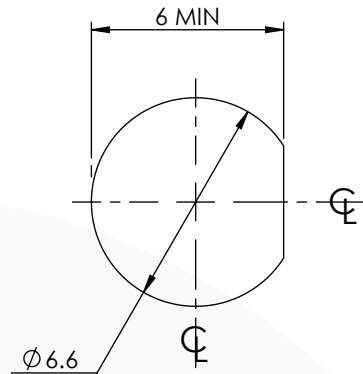

RECOMMENDED TORQUE FOR PANEL NUT: 1.35-1.7 Nm

MAXIMUM PANEL THICKNESS: 5.0mm

Environmental Specification

Operating Temp: -55 to +155 Deg C.

IP Rating (unmated): IP 68 @ 50m

Electrical Specification

Impedance: 50 Ohm

Frequency: 0-6 GHz

Dielectric W/V: 1000 Veff

Insulation res: 5000 M-Ohm

Mechanical Specification

Contact Retention: 27 N min

Cable Retention: N/A

Mating cycles: 500

Weight: 6.96 g

Connector Interface

image for illustration purposes only

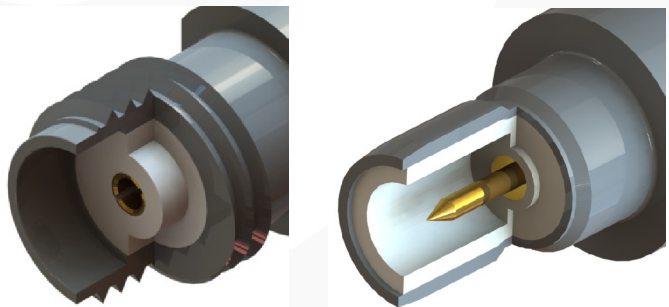

7	INTERNAL SEAL	EPOXY	N/A
6	LOCKWASHER	ST. STEEL	PASSIVATED
5	GASKET	SILICONE	N/A
4	NUT	ST. STEEL	PASSIVATED
3	INSULATOR	PTFE	N/A
2	CENTRE CONTACT	BERYLLIUM COPPER	GOLD
1	BODY	ST. STEEL	GOLD
ITEM	DESCRIPTION	MATERIAL	PLATING

A4	SHEET 1 OF 1	DIMENSIONS ARE IN MILLIMETRES		
REVISION :	A00	NAME	SIGNATURE	DATE
ISSUE :	1	DRAWN	G.E.	29/09/2022
		CHK'D	P.S.	29/09/2022
		APPV'D		
<p>6-8 COLNE ROAD, TWICKENHAM, MIDDLESEX. TW1 4JR</p> <p>THE INFORMATION IS GIVEN AS AN INDICATION ONLY AND IS SUBJECT TO CHANGE WITHOUT NOTICE. IN THE CONTINUAL GOAL TO IMPROVE OUR PRODUCTS, WE RESERVE THE RIGHT TO MAKE ANY MODIFICATIONS NECESSARY WITHOUT PRIOR NOTICE.</p>				