

MICRO BNC ANGLED PCB BULKHEAD JACK

67-492-1-D66

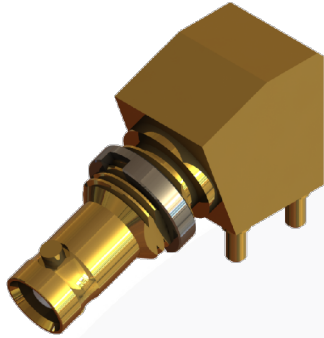

images for illustration purposes only

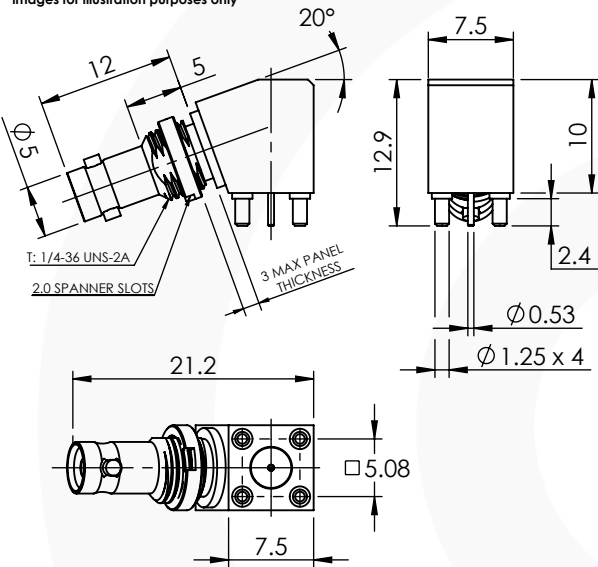

Recommended Mounting Hole

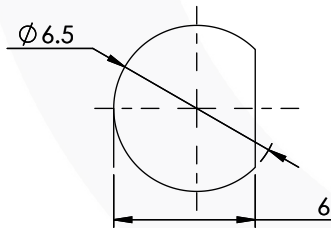

Recommended PCB Layout

Not Applicable

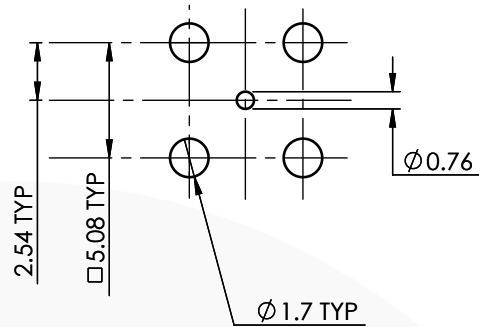

Tooling

- Centre Contact: Not Applicable Tool No: Not Applicable
- Crimp Sleeve: Not Applicable Tool No: Not Applicable
- Castellated Nut Spanner: 96-1135 (MAX TORQUE - 115Ncm)

Environmental Specification

Operating Temp: -55 to +155 Deg C.
IP Rating (Mated): IP 54

Electrical Specification

Impedance: 75 Ohm
Frequency: 0-6 GHz
Dielectric W/V: 1000 Veff
Insulation res: 5000 M-Ohm

Mechanical Specification

Contact Retention: 15 N min
Cable Retention: Not Applicable
Mating cycles: 500
Weight: 6.39 g

Connector Interface

image for illustration purposes only

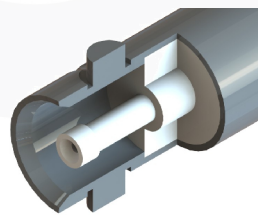

5	NUT	BRASS	NICKEL
4	REAR BODY	BRASS	GOLD
3	INSULATOR	PTFE	N/A
2	CENTRE CONTACT	BERYLLIUM COPPER	GOLD
1	BODY	BRASS	GOLD
ITEM	DESCRIPTION	MATERIAL	PLATING

A4	SHEET 1 OF 1	DIMENSIONS ARE IN MILLIMETRES		
REVISION :	A00	NAME	SIGNATURE	DATE
ISSUE :	1	DRAWN	G.E.	29/05/2022
		CHK'D	P.S.	29/05/2022
		APPV'D		
6-8 COLNE ROAD, TWICKENHAM, MIDDLESEX, TW1 4JR <small>THE INFORMATION IS GIVEN AS AN INDICATION ONLY AND IS SUBJECT TO CHANGE WITHOUT NOTICE. IN THE CONTINUAL GOAL TO IMPROVE OUR PRODUCTS, WE RESERVE THE RIGHT TO MAKE ANY MODIFICATIONS NECESSARY WITHOUT PRIOR NOTICE.</small>				