

## SMB STRAIGHT PCB PLUG

### 32-400-D3

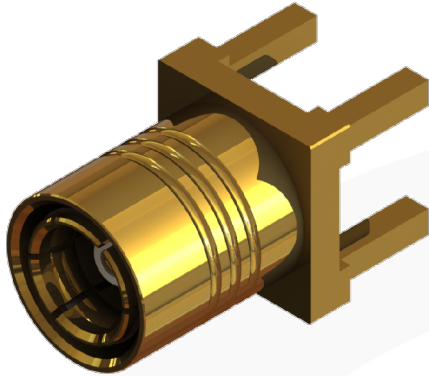

images for illustration purposes only

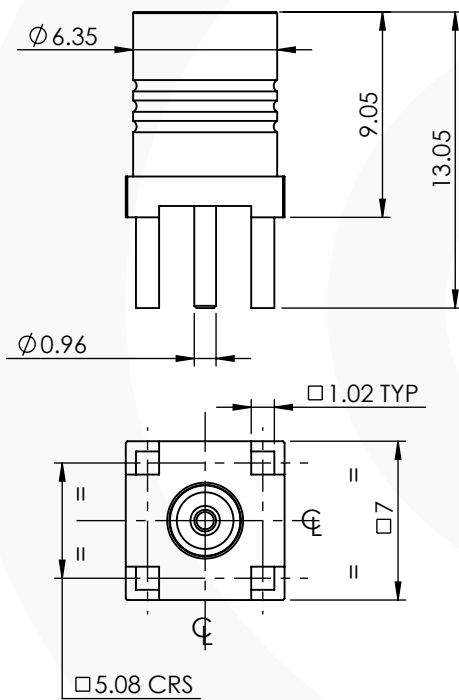

### Mounting Dimensions

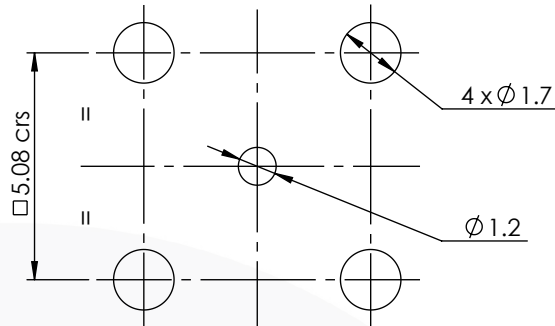

### Assembly Procedure:

#### Tooling

- Centre Contact: Solder Tool No: Solder
- Crimp Sleeve: Not Applicable Tool No: Not Applicable
- Alignment Tool: Not Applicable Extraction: Not Applicable

#### Environmental Specification

Operating Temp: -55 to +155 Deg C.  
IP Rating (Mated): IP 44

#### Electrical Specification

Impedance: 50 Ohm  
Frequency: 0-4 GHz  
Dielectric W/V: 1000 Veff  
Insulation res: 1000 M-Ohm

#### Mechanical Specification

Contact Retention: 10 N min  
Cable Retention: N/A N min  
Mating cycles: 500  
Weight: 1.71 g

#### Connector Interface

image for illustration purposes only

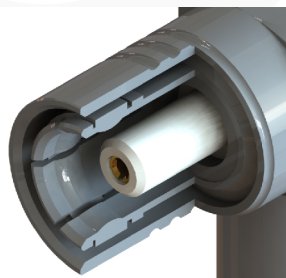

6	BODY	BRASS	GOLD
3	INSULATOR	PTFE	N/A
2	CENTRE CONTACT	BERYLLIUM COPPER	GOLD
1	RESILIENT RING	BERYLLIUM COPPER	NICKEL
ITEM	DESCRIPTION	MATERIAL	PLATING

<b>A4</b>	SHEET 1 OF 1	DIMENSIONS ARE IN MILLIMETRES		
REVISION :	A00	NAME	SIGNATURE	DATE
ISSUE :	2	DRAWN	G.E.	29/09/2022
		CHK'D	P.S.	29/09/2022
		APPV'D		
<p>6-8 COLNE ROAD, TWICKENHAM, MIDDLESEX. TW1 4JR</p> <p>THE INFORMATION IS GIVEN AS AN INDICATION ONLY AND IS SUBJECT TO CHANGE WITHOUT NOTICE. IN THE CONTINUAL GOAL TO IMPROVE OUR PRODUCTS, WE RESERVE THE RIGHT TO MAKE ANY MODIFICATIONS NECESSARY WITHOUT PRIOR NOTICE.</p>				