

SMA STRAIGHT BULKHEAD CRIMP/CRIMP JACK

30-266-D3-HA

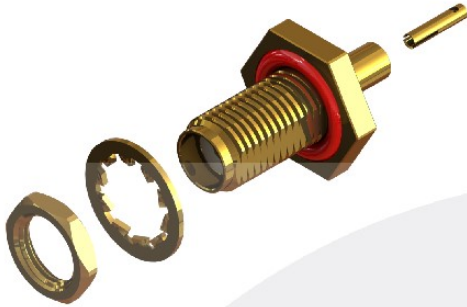

images for illustration purposes only

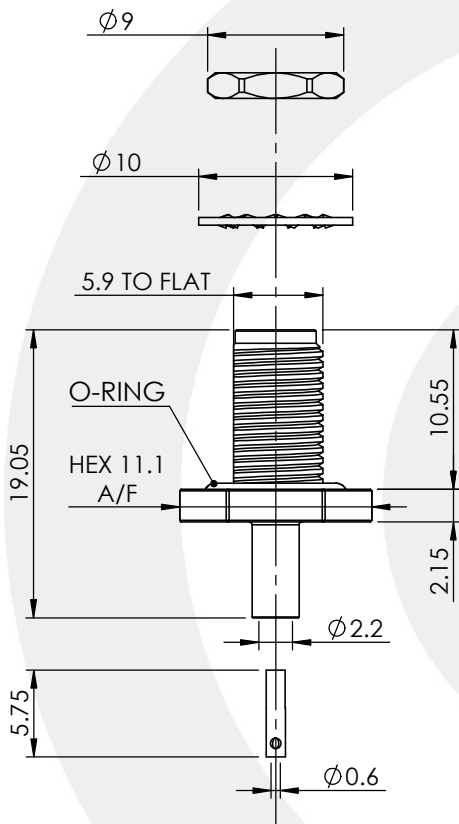

Suitable for Cables:

(HA) RG405 (0.085"), UT85

Stripping Dimensions

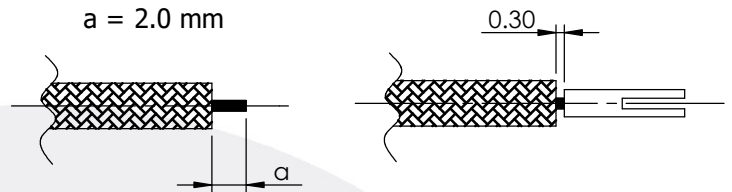

Assembly Procedure:

Tooling

Centre Contact: Solder

Tool No: Not Applicable

Crimp Sleeve: Not Applicable

Tool No: Not Applicable

Environmental Specification

Operating Temp: -55 to +155 Deg C.

IP Rating (Mated): IP 65

Electrical Specification

Impedance: 50 Ohm

Frequency: 0-18 GHz

Dielectric W/V: 1000 Veff

Insulation res: 5000 M-Ohm

Mechanical Specification

Contact Retention: 27 N min

Cable Retention: 100 N min

Mating cycles: 100

Weight: 3.90 g

Connector Interface

image for illustration purposes only



Recommended Mounting Hole

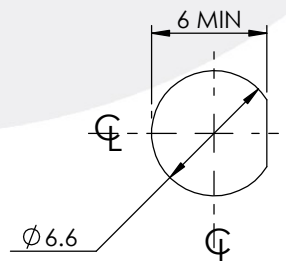

RECOMMENDED TORQUE FOR PANEL NUT : 150Ncm

6	WASHER	ST. STL.	GOLD
5	NUT	BRASS	GOLD
4	GASKET	SILICONE	N/A
3	INSULATOR	PTFE	N/A
2	CENTRE CONTACT	BeCu	GOLD
1	BODY	BRASS	GOLD
ITEM	DESCRIPTION	MATERIAL	PLATING

A4	SHEET 1 OF 1	 DIMENSIONS ARE IN MILLIMETRES		
REVISION :	B00	NAME	SIGNATURE	DATE
ISSUE :	1	DRAWN	G.E.	23/11/2021
		CHK'D	P.S.	23/11/2021
		APPV'D		
6-8 COLNE ROAD, TWICKENHAM, MIDDLESEX. TW1 4JR				
<small>THE INFORMATION IS GIVEN AS AN INDICATION ONLY AND IS SUBJECT TO CHANGE WITHOUT NOTICE. IN THE CONTINUAL GOAL TO IMPROVE OUR PRODUCTS, WE RESERVE THE RIGHT TO MAKE ANY MODIFICATIONS NECESSARY WITHOUT PRIOR NOTICE.</small>				