

SMA STRAIGHT CRIMP / CRIMP PLUG 30-005-D3-DE

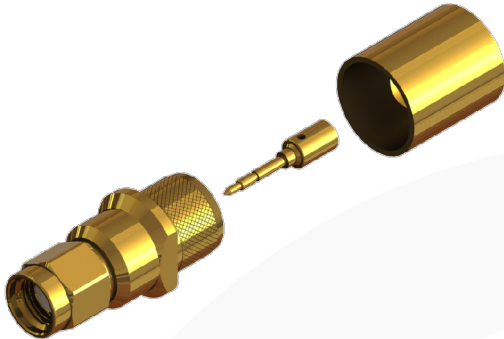

images for illustration purposes only

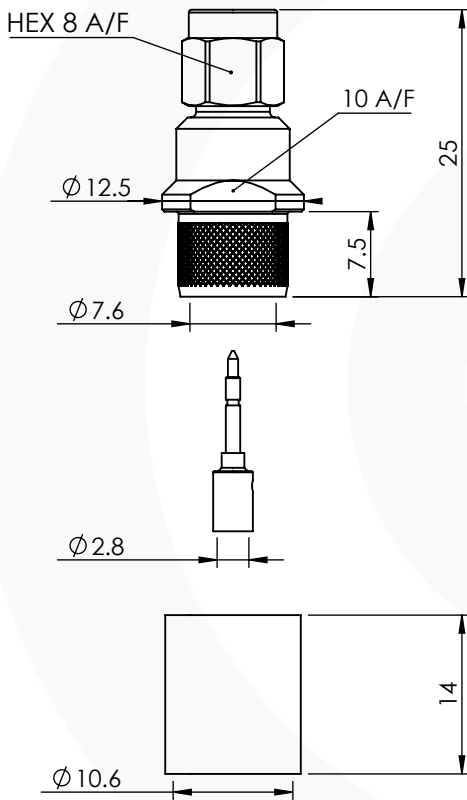

Suitable for Cables:

(DE) LMR400, TZC50032, Belden 9913, RG8

Stripping Dimensions

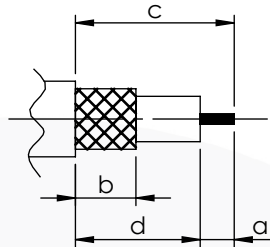

Assembly Procedure: AP001

Tooling

Centre Contact: Hex 3.25mm A/F or Solder Tool No: 336K or Solder

Crimp Sleeve: Hex 10.9mm A/F Tool No: 336K

NOTE : FOR COPPER CLAD ALUMINIUM CABLES ie LMR400 WE RECOMMEND SOLDERING CENTRE CONTACT

Environmental Specification

Operating Temp: -55 to +155 Deg C.

IP Rating (Mated): IP 40

Electrical Specification

Impedance: 50 Ohm

Frequency: 0-12 GHz

Dielectric W/V: 1000 Veff

Insulation res: 5000 M-Ohm

Mechanical Specification

Contact Retention: 15 N min

Cable Retention: 200 N min

Mating cycles: 250

Weight: 10.25 g

Connector Interface

image for illustration purposes only

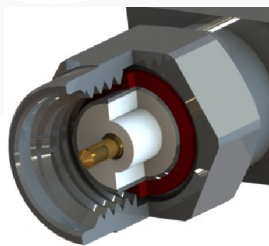

5	GASKET	SILICONE	N/A
4	CRIMP SLEEVE	BRASS	GOLD
3	INSULATOR	PTFE	N/A
2	CENTRE CONTACT	BRASS	GOLD
1	BODY	BRASS	GOLD
ITEM	DESCRIPTION	MATERIAL	PLATING

A4	SHEET 1 OF 1	DIMENSIONS ARE IN MILLIMETRES		
REVISION :	A00	NAME	SIGNATURE	DATE
ISSUE :	1	DRAWN	G.E.	12/04/2023
		CHK'D	P.S.	12/04/2023
		APPV'D		
6-8 COLNE ROAD, TWICKENHAM, MIDDLESEX. TW1 4JR				
THE INFORMATION IS GIVEN AS AN INDICATION ONLY AND IS SUBJECT TO CHANGE WITHOUT NOTICE. IN THE CONTINUAL GOAL TO IMPROVE OUR PRODUCTS, WE RESERVE THE RIGHT TO MAKE ANY MODIFICATIONS NECESSARY WITHOUT PRIOR NOTICE.				