

N TYPE FRONT MOUNT JACK WITH SOLDER CUP 25-294-Q3

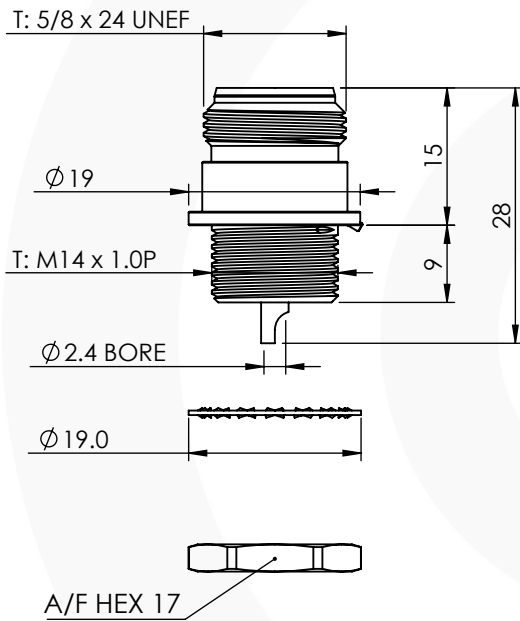

images for illustration purposes only



Recommended Mounting Hole

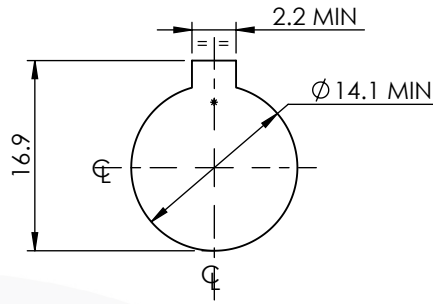

MAX. PANEL THICKNESS: 4.5mm

Environmental Specification

Operating Temp: -55 to +155 Deg C.
IP Rating (Mated): IP 40

Electrical Specification

Impedance: 50 Ohm
Frequency: 0-11 GHz
Dielectric W/V: 2500 Veff
Insulation res: 5000 M-Ohm

Mechanical Specification

Contact Retention: 27 N min
Cable Retention: Not Applicable
Mating cycles: 500
Weight: 26.94 g

Connector Interface

image for illustration purposes only

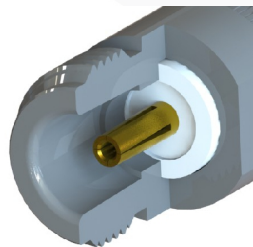

6	WASHER	STAINLESS STEEL	WHITE BRONZE
4	NUT	BRASS	WHITE BRONZE
3	INSULATOR	PTFE	N/A
2	CENTRE CONTACT	PHOS. BRONZE	GOLD
1	BODY	BRASS	WHITE BRONZE
ITEM	DESCRIPTION	MATERIAL	PLATING

A4	SHEET 1 OF 1	DIMENSIONS ARE IN MILLIMETRES		
REVISION :	A01	NAME	SIGNATURE	DATE
ISSUE :	1	DRAWN	G.E.	06/10/2021
		CHK'D	P.S.	06/10/2021
		APPV'D		
6-8 COLNE ROAD, TWICKENHAM, MIDDLESEX. TW1 4JR		THE INFORMATION IS GIVEN AS AN INDICATION ONLY AND IS SUBJECT TO CHANGE WITHOUT NOTICE. IN THE CONTINUAL GOAL TO IMPROVE OUR PRODUCTS, WE RESERVE THE RIGHT TO MAKE ANY MODIFICATIONS NECESSARY WITHOUT PRIOR NOTICE.		