

N TYPE BULKHEAD JACK TO JACK ADAPTOR 25-501-1-B3

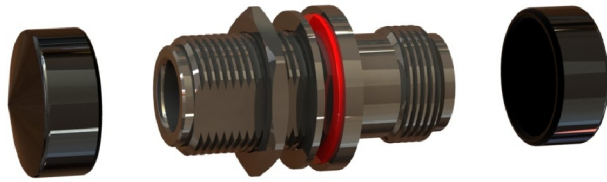

images for illustration purposes only

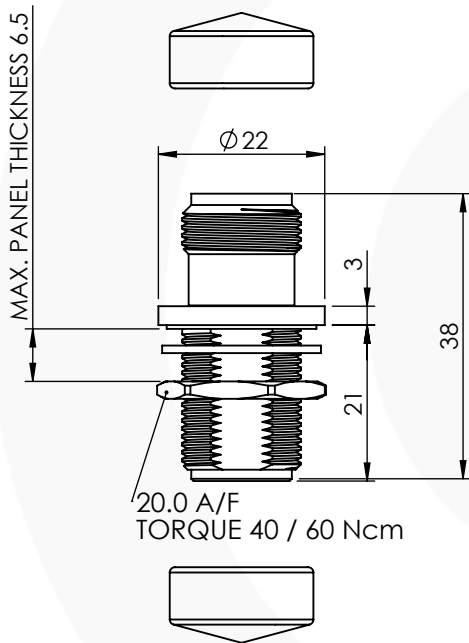

Recommended Mounting Hole

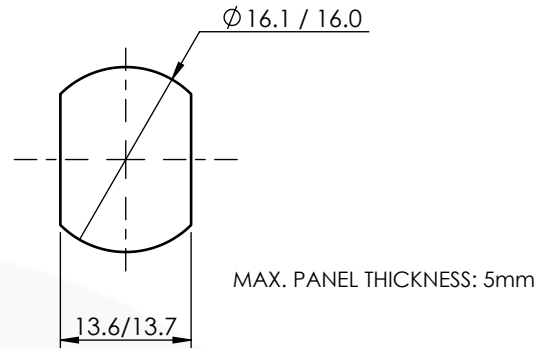

Tooling

Centre Contact: Not Applicable Tool No: Not Applicable

Crimp Sleeve: Not Applicable Tool No: Not Applicable

Environmental Specification

Operating Temp: -55 to +155 Deg C.

IP Rating (Mated): IP 68

Electrical Specification

Impedance: 50 Ohm

Frequency: 0-11 GHz

Dielectric W/V: 1500 Veff

Insulation res: 5000 M-Ohm

Mechanical Specification

Contact Retention: 10 N min

Cable Retention: N/A N min

Mating cycles: 500

Weight: 47.49 g

Connector Interface

image for illustration purposes only

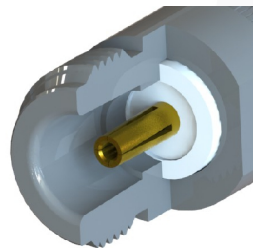

Performance

-31.6 dB @ 3.0 GHz

-28.1 dB @ 6.0 GHz

-16.1 dB @ 9.0 GHz

-28.3 dB @ 12.0GHz

Return Loss Graph

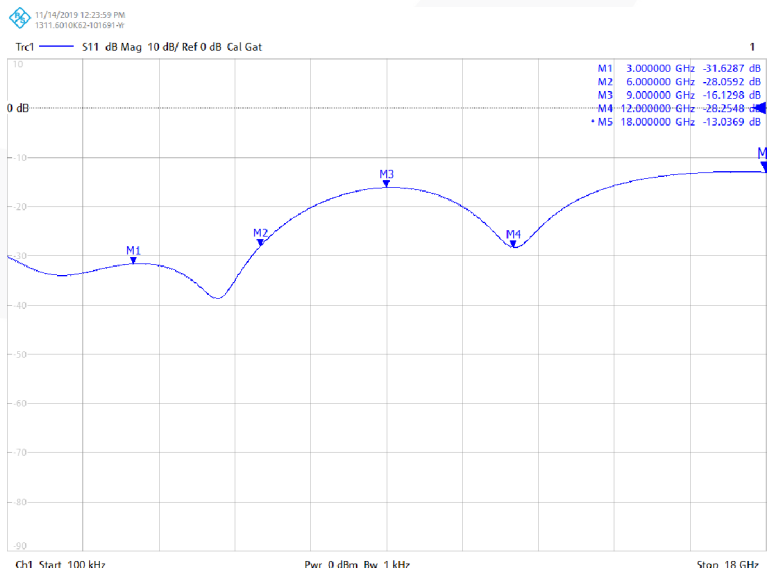

ITEM	DESCRIPTION	MATERIAL	PLATING
6	WASHER	BRASS	NICKEL
5	GASKET	SILICONE	N/A
4	NUT	BRASS	NICKEL
3	INSULATOR	PTFE	N/A
2	CENTRE CONTACT	PHOS. BRONZE	GOLD
1	BODY	BRASS	NICKEL

A4 SHEET 1 OF 1		DIMENSIONS ARE IN MILLIMETRES		
REVISION :	A01	NAME	SIGNATURE	DATE
DRAWN	IG			06/06/2012
ISSUE :	3	CHK'D	GE	13/06/2012
6-8 COLNE ROAD, TWICKENHAM, MIDDLESEX. TW1 4JR		APPV'D		

THE INFORMATION IS GIVEN AS AN INDICATION ONLY AND IS SUBJECT TO CHANGE WITHOUT NOTICE. IN THE CONTINUAL GOAL TO IMPROVE OUR PRODUCTS, WE RESERVE THE RIGHT TO MAKE ANY MODIFICATIONS NECESSARY WITHOUT PRIOR NOTICE.