

BMA STRAIGHT EASYFIT/SOLDER FLOATING BULKHEAD JACK 57-267-D3-HA

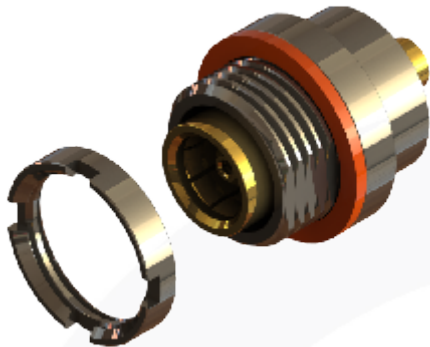

images for illustration purposes only

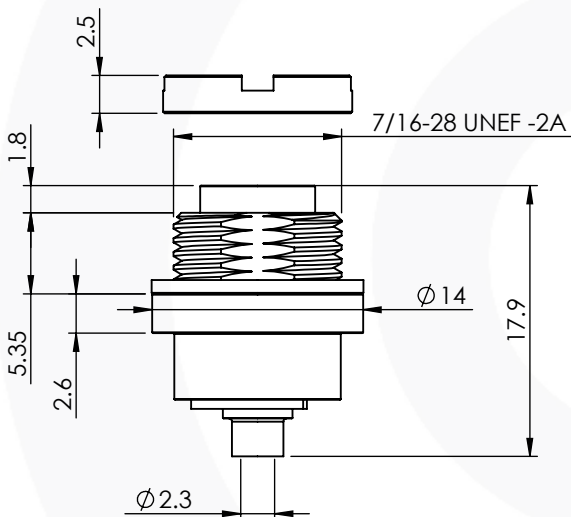

Suitable for Cables:

(HA) RG405 (0.085"), UT85

Stripping Dimensions

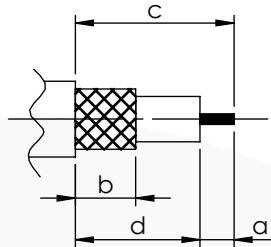

a = 4.0 mm
b = 9.0 mm
c = 13.0 mm
d = 9.0 mm

} IF SHEATHED
CABLE IS USED

* CUT FOIL TO DIM. "b"

Assembly Procedure: TBC

Tooling

Centre Contact: Not Applicable Tool No: Not Applicable

Crimp Sleeve: Solder Tool No: Not Applicable

Alignment Tool: Not Applicable Extraction: Not Applicable

Environmental Specification

Operating Temp: -55 to +155 Deg C.

IP Rating (Mated): NONE

Electrical Specification

Impedance: 50 Ohm

Frequency: 0 - 6 GHz

Dielectric W/V: 1000 Veff

Insulation res: 5000 M-Ohm

Mechanical Specification

Contact Retention: 27 N min

Cable Retention: 100 N min

Mating cycles: 500

Weight: 8.03 g

Connector Interface

image for illustration purposes only

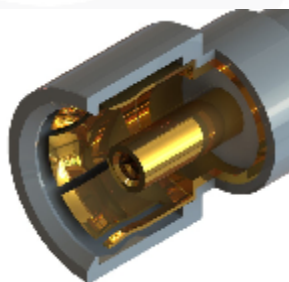

Recommended Mounting

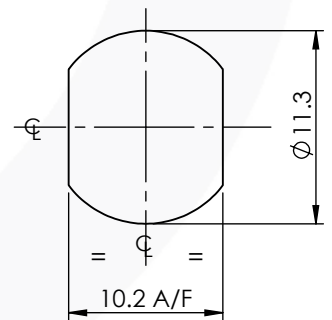

10	WASHER	RED FIBRE	N/A
9	NUT	BRASS	NICKEL
8	MALE CONTACT	BRASS	GOLD
7	CENTRE CONTACT	BRASS	GOLD
6	CENTRE CONTACT SLEEVE	BeCu	GOLD
5	INSULATOR	PTFE	N/A
4	SPRING	SUS304	ZINC
3	OUTER BODY	BRASS	GOLD
2	E - CLIP	SUS304	ZINC
1	BACK BODY	BRASS	NICKEL
ITEM	DESCRIPTION	MATERIAL	PLATING

A4	SHEET 1 OF 1	DIMENSIONS ARE IN MILLIMETRES		
REVISION :	A00	NAME	SIGNATURE	DATE
ISSUE :	2	DRAWN	G.E.	06/05/20
		CHK'D	P.P.	21/10/10
		APPV'D		
6-8 COLNE ROAD, TWICKENHAM, MIDDLESEX. TW1 4JR				
THE INFORMATION IS GIVEN AS AN INDICATION ONLY AND IS SUBJECT TO CHANGE WITHOUT NOTICE. IN THE CONTINUAL GOAL TO IMPROVE OUR PRODUCTS, WE RESERVE THE RIGHT TO MAKE ANY MODIFICATIONS NECESSARY WITHOUT PRIOR NOTICE.				