

BT43 STRAIGHT CRIMP/CRIMP PLUG 43-011-D6-BJ

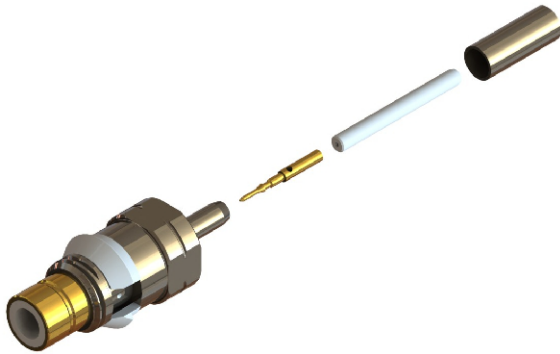

images for illustration purposes only

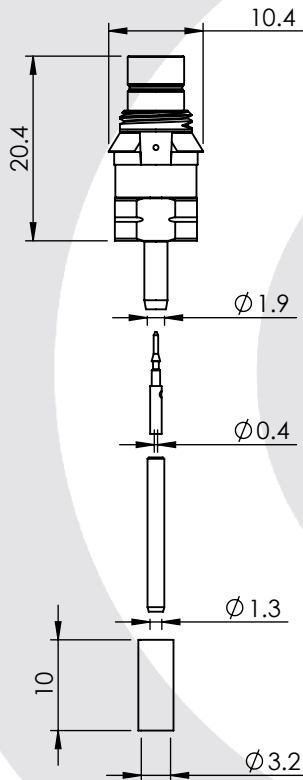

Suitable for Cables:

(BJ) 2.2mm Dia Mini Coax, Saturn, 3M-043, GCX0379

Stripping Dimensions

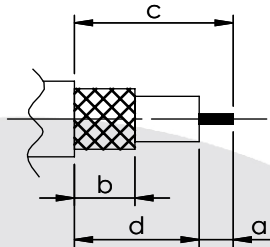

a = 4.5 mm
b = 8.0 mm
c = 21.0 mm
d = 16.5 mm

* CUT FOIL TO DIM. "b"

Assembly Procedure: AP024

Tooling

Centre Contact: Square Crimp Tool No: HTS-43

Crimp Sleeve: HEX 3.25mm A/F Tool No: HTS-43

Alignment Tool: Not Applicable Extraction: 96-831-TOOL

Environmental Specification

Operating Temp: -40 TO +100 Deg C

IP Rating (Mated): NONE

Electrical Specification

Impedance: 75 Ohm

Frequency: 0-3 GHz

Dielectric W/V: 1500 Veff

Insulation res: 5000 M-Ohm

Mechanical Specification

Contact Retention: 22 N min

Cable Retention: 60 N min

Mating cycles: 250

Weight: 6.75 g

Connector Interface

image for illustration purposes only

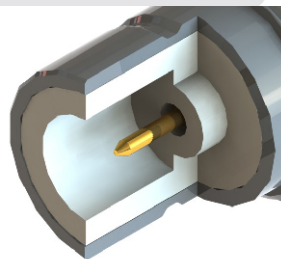

6	PUSHER SLEEVE	PTFE	N/A
5	RETAINING RING	PBT	N/A
4	CRIMP SLEEVE	BRASS	NICKEL
3	INSULATOR	PTFE	N/A
2	CENTRE CONTACT	PHOSPHOR BRONZE	GOLD
1	BODY	BRASS	NICKEL/GOLD
ITEM	DESCRIPTION	MATERIAL	PLATING

A4	SHEET 1 OF 1	 DIMENSIONS ARE IN MILLIMETRES		
REVISION :	A01	NAME	SIGNATURE	DATE
DRAWN	GE			16/10/2009
ISSUE :	2	CHK'D	PS	16/10/2009
		APPV'D		
6-8 COLNE ROAD, TWICKENHAM, MIDDLESEX. TW1 4JR				
THE INFORMATION IS GIVEN AS AN INDICATION ONLY AND IS SUBJECT TO CHANGE WITHOUT NOTICE. IN THE CONTINUAL GOAL TO IMPROVE OUR PRODUCTS, WE RESERVE THE RIGHT TO MAKE ANY MODIFICATIONS NECESSARY WITHOUT PRIOR NOTICE.				