

## BT43 STRAIGHT CRIMP/CRIMP PLUG 43-011-D6-BG

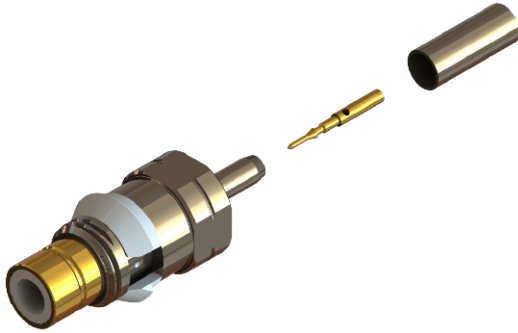

images for illustration purposes only

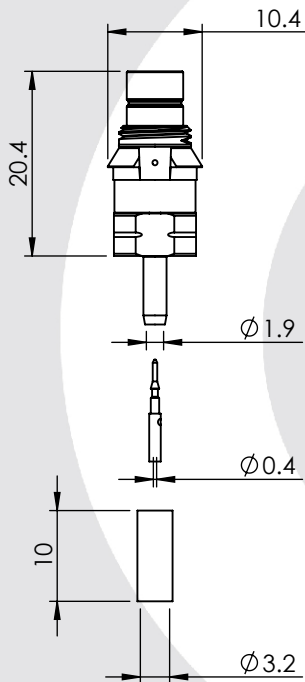

### Suitable for Cables:

(BG) RA8000

### Stripping Dimensions

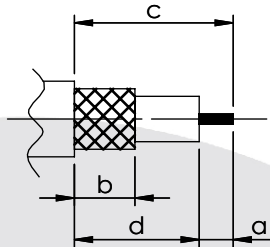

a = 4.5 mm  
b = 8.0 mm  
c = 21.0 mm  
d = 16.5 mm

\* CUT FOIL TO DIM. "b"

### Assembly Procedure: AP023

### Tooling

Centre Contact: Square Crimp      Tool No: HTS-43

Crimp Sleeve: HEX 3.25mm A/F      Tool No: HTS-43

Alignment Tool: Not Applicable      Extraction: 96-831-TOOL

### Environmental Specification

Operating Temp: -40 TO +100 Deg C

IP Rating (Mated): NONE

### Electrical Specification

Impedance: 75 Ohm

Frequency: 0-3 GHz

Dielectric W/V: 1500 Veff

Insulation res: 5000 M-Ohm

### Mechanical Specification

Contact Retention: 22 N min

Cable Retention: 60 N min

Mating cycles: 250

Weight: 6.73 g

### Connector Interface

image for illustration purposes only

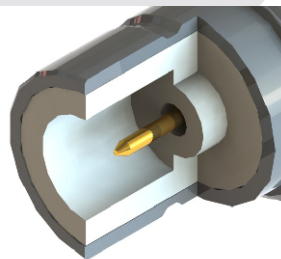

| 6    |                |                 |             |
|------|----------------|-----------------|-------------|
| 5    | RETAINING RING | PBT             | N/A         |
| 4    | CRIMP SLEEVE   | BRASS           | NICKEL      |
| 3    | INSULATOR      | PTFE            | N/A         |
| 2    | CENTRE CONTACT | PHOSPHOR BRONZE | GOLD        |
| 1    | BODY           | BRASS           | NICKEL/GOLD |
| ITEM | DESCRIPTION    | MATERIAL        | PLATING     |

|  |              |                               |        |           |            |
|--|--------------|-------------------------------|--------|-----------|------------|
| <b>A4</b>  | SHEET 1 OF 1 | DIMENSIONS ARE IN MILLIMETRES |        |           |            |
| REVISION :   | A02          |                               | NAME   | SIGNATURE | DATE       |
| DRAWN :  | 2            |                               | GE     |           | 16/10/2009 |
| ISSUE :  |              |                               | CHK'D  | PS        | 16/10/2009 |
|  |              |                               | APPV'D |           |            |
| <b>6-8 COLNE ROAD,<br/>TWICKENHAM,<br/>MIDDLESEX.<br/>TW1 4JR</b>  |              |                               |        |           |            |
| <small>THE INFORMATION IS GIVEN AS AN INDICATION ONLY AND IS SUBJECT TO CHANGE WITHOUT NOTICE. IN THE CONTINUAL GOAL TO IMPROVE OUR PRODUCTS, WE RESERVE THE RIGHT TO MAKE ANY MODIFICATIONS NECESSARY WITHOUT PRIOR NOTICE.</small> |              |                               |        |           |            |