

TNC STRAIGHT FRONT MOUNT BULKHEAD SOLDER JACK

13-352-A3

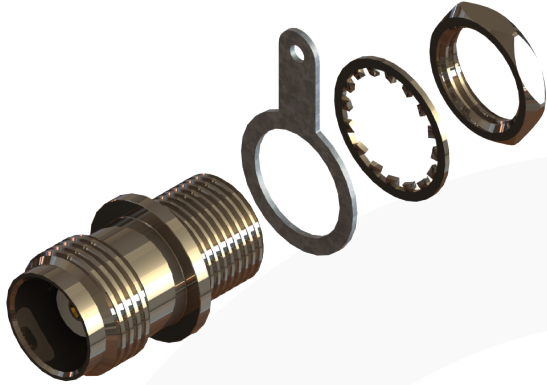

images for illustration purposes only

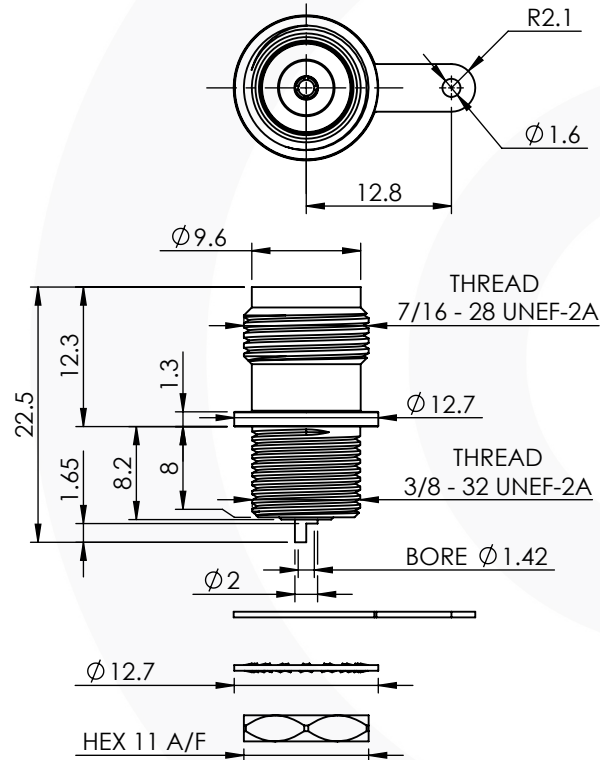

Recommended Mounting

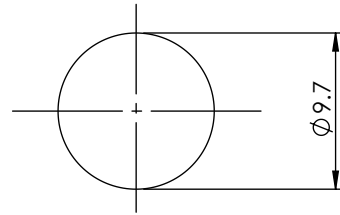

MAX PANEL THICKNESS = 5mm

Tooling

Centre Contact: Solder Tool No: Solder
 Crimp Sleeve: Not Applicable Tool No: Not Applicable
 Alignment Tool: Not Applicable Extraction: Not Applicable

Environmental Specification

Operating Temp: -55 to +155 Deg C.
 IP Rating (Mated): IP 40

Electrical Specification

Impedance: 50 Ohm
 Frequency: 0-4 GHz
 Dielectric W/V: 1500 Veff
 Insulation res: 5000 M-Ohm

Mechanical Specification

Contact Retention: 10 N min
 Cable Retention: Not Applicable
 Mating cycles: 500
 Weight: 9.09 g

Connector Interface

image for illustration purposes only

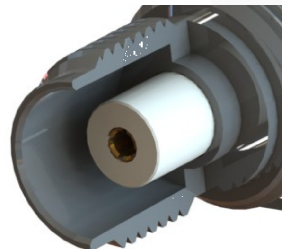

ITEM	DESCRIPTION	MATERIAL	PLATING
6	WASHER	Fe	NICKEL
5	NUT	BRASS	NICKEL
4	SOLDER TAG	BRASS	TIN
3	INSULATOR	PTFE	N/A
2	CENTRE CONTACT	PHOSPHOR BRONZE	GOLD
1	BODY	BRASS	NICKEL

A4 SHEET 1 OF 1		DIMENSIONS ARE IN MILLIMETRES		
REVISION :	A00	NAME	SIGNATURE	DATE
ISSUE :	1	DRAWN	G.E.	06/11/18
		CHK'D	B.S.	06/11/18
		APPV'D		

6-8 COLNE ROAD,
 TWICKENHAM,
 MIDDLESEX.
 TW1 4JR

THE INFORMATION IS GIVEN AS AN INDICATION ONLY AND IS SUBJECT TO CHANGE WITHOUT NOTICE. IN THE CONTINUAL GOAL TO IMPROVE OUR PRODUCTS, WE RESERVE THE RIGHT TO MAKE ANY MODIFICATIONS NECESSARY WITHOUT PRIOR NOTICE.