

TNC STRAIGHT CRIMP / CRIMP PLUG 13-005-B3-AV

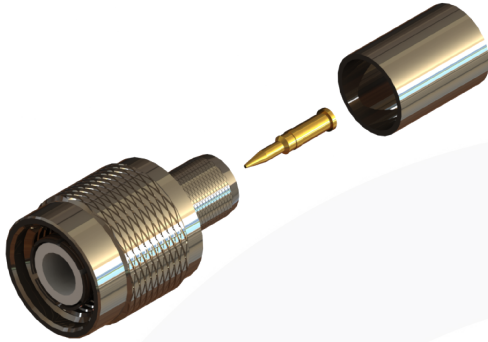

images for illustration purposes only

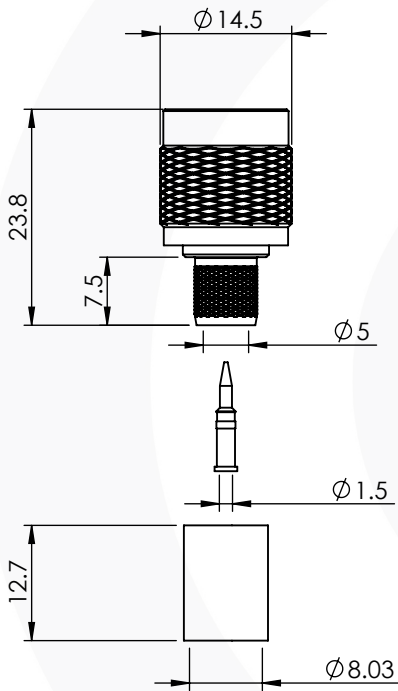

Suitable for Cables:

(AV) ECX 5D-2V

Stripping Dimensions

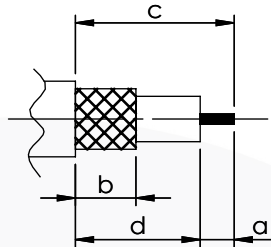

a = 4.0 mm
b = 8.0 mm
c = 16.0 mm
d = 12.0 mm

Assembly Procedure: AP001

Tooling

Centre Contact: Hex 1.72mm A/F Tool No: 96-HTS-75A

Crimp Sleeve: Hex 8.23mm A/F Tool No: 96-HTS-75A

Alignment Tool: Not Applicable Extraction: Not Applicable

Environmental Specification

Operating Temp: -55 to +155 Deg C.

IP Rating (Mated): IP 65

Electrical Specification

Impedance: 50 Ohm

Frequency: 0-11 GHz

Dielectric W/V: 1500 Veff

Insulation res: 5000 M-Ohm

Mechanical Specification

Contact Retention: 10 N min

Cable Retention: 150 N min

Mating cycles: 500

Weight: 14.02 g

Connector Interface

image for illustration purposes only

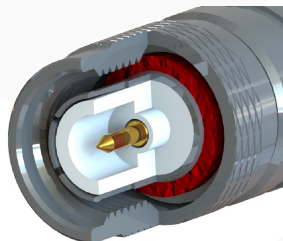

7	INNER RETAINING RING	SK5	NICKEL
6	COUPLING NUT	BRASS	NICKEL
5	GASKET	SILICONE	N/A
4	CRIMP SLEEVE	BRASS	NICKEL
3	INSULATOR	PTFE	N/A
2	CENTRE CONTACT	BRASS	GOLD
1	BODY	BRASS	NICKEL
ITEM	DESCRIPTION	MATERIAL	PLATING

A4	SHEET 1 OF 1	DIMENSIONS ARE IN MILLIMETRES		
REVISION :	A00	NAME	SIGNATURE	DATE
ISSUE :	2	DRAWN	G.E.	17/10/19
		CHK'D	P.P.	17/10/19
		APPV'D		
6-8 COLNE ROAD, TWICKENHAM, MIDDLESEX. TW1 4JR				
THE INFORMATION IS GIVEN AS AN INDICATION ONLY AND IS SUBJECT TO CHANGE WITHOUT NOTICE. IN THE CONTINUAL GOAL TO IMPROVE OUR PRODUCTS, WE RESERVE THE RIGHT TO MAKE ANY MODIFICATIONS NECESSARY WITHOUT PRIOR NOTICE.				