

1.0/2.3 STRAIGHT CRIMP/CRIMP PLUG 52-005-B6-FE

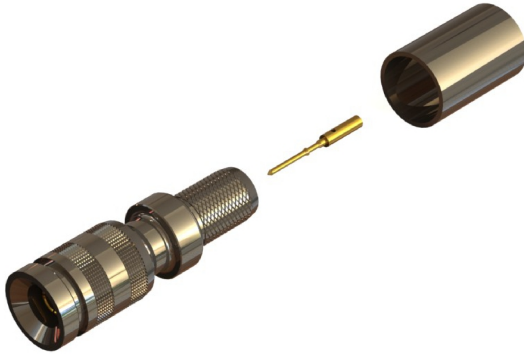

images for illustration purposes only

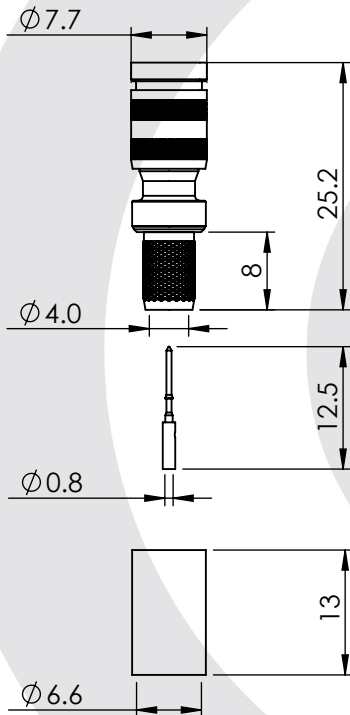

Suitable for Cables:

(FE) Belden 1505F

Stripping Dimensions

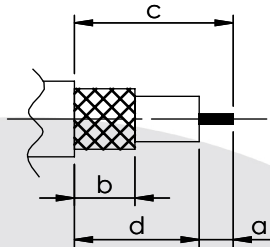

a = 3.5 mm
* b = 8.0 mm
c = 15.0 mm
d = 11.5 mm

* STRIP FOIL
SCREEN TO
DIM "b"

Assembly Procedure: AP026

Tooling

Centre Contact: SQ 0.95mm A/F Tool No: 96-HTS-76

Crimp Sleeve: HEX 6.48mm A/F Tool No: 96-HTS-76

Alignment Tool: 100-1023 Extraction: 96-1023

Environmental Specification

Operating Temp: -55 to +155 Deg C.

IP Rating (Mated): IP 40

Electrical Specification

Impedance: 75 Ohm

Frequency: 0-3 GHz

Dielectric W/V: 750 Veff

Insulation res: 5000 M-Ohm

Mechanical Specification

Contact Retention: 10 N min

Cable Retention: 150 N min

Mating cycles: 500

Weight: 5.35 g

Connector Interface

image for illustration purposes only

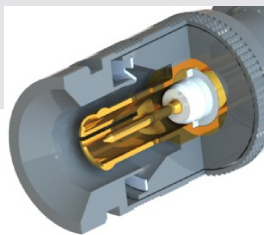

8	REAR BODY	BRASS	NICKEL
7	OUTER CONTACT	BERYLLIUM COPPER	GOLD
6	CENTRE CONTACT	PHOSPHOR BRONZE	GOLD
5	SPRING	BERYLLIUM COPPER	NICKEL
4	CRIMP SLEEVE	BRASS	NICKEL
3	BODY	BRASS	NICKEL
2	INSULATOR	PTFE	N/A
1	COUPLING NUT	BRASS	NICKEL
ITEM	DESCRIPTION	MATERIAL	PLATING

A4	SHEET 1 OF 1	 DIMENSIONS ARE IN MILLIMETRES		
REVISION :	B00	NAME	SIGNATURE	DATE
ISSUE :	1	DRAWN	GE	28/11/2012
		CHK'D	IG	28/11/2012
		APP'V'D		
6-8 COLNE ROAD, TWICKENHAM, MIDDLESEX. TW1 4JR				
THE INFORMATION IS GIVEN AS AN INDICATION ONLY AND IS SUBJECT TO CHANGE WITHOUT NOTICE. IN THE CONTINUAL GOAL TO IMPROVE OUR PRODUCTS, WE RESERVE THE RIGHT TO MAKE ANY MODIFICATIONS NECESSARY WITHOUT PRIOR NOTICE.				