

## SMB SMT JACK

### 32-458-D3

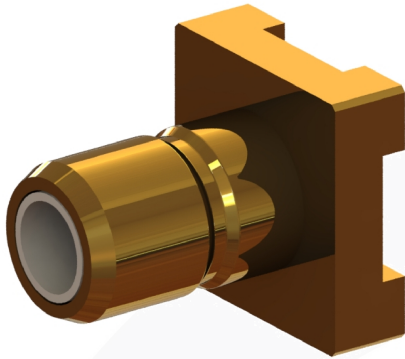

images for illustration purposes only

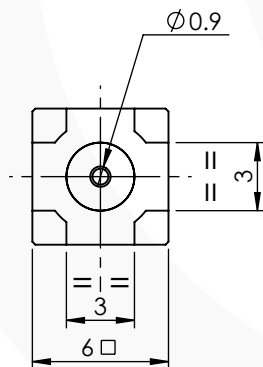
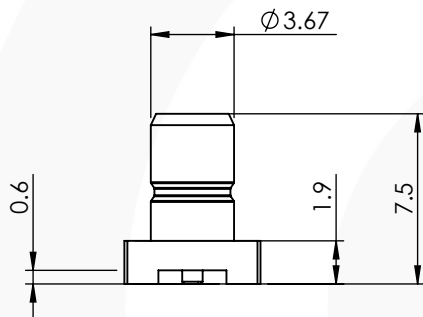

### Recommended PCB Layout

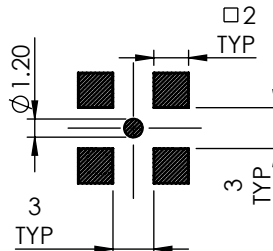

### Environmental Specification

Operating Temp: -55 to +155 Deg C.  
IP Rating (Mated): IP 40

### Electrical Specification

Impedance: 50 Ohm  
Frequency: 0-4 GHz  
Dielectric W/V: 1000 Veff  
Insulation res: 5000 M-Ohm

### Mechanical Specification

Contact Retention: 10 N min  
Cable Retention: N/A  
Mating cycles: 500  
Weight: 0.66 g

### Connector Interface

image for illustration purposes only

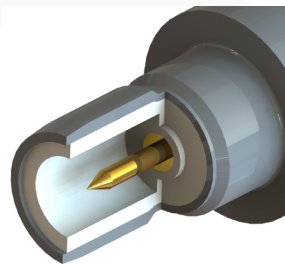

3	INSULATOR	PTFE	N/A
2	CENTRE CONTACT	BRASS	GOLD
1	BODY	BRASS	GOLD
ITEM	DESCRIPTION	MATERIAL	PLATING

<b>A4</b>	SHEET 1 OF 1	DIMENSIONS ARE IN MILLIMETRES		
REVISION :	A00	NAME	SIGNATURE	DATE
ISSUE :	2	DRAWN	P.P.	07/02/2019
6-8 COLNE ROAD, TWICKENHAM, MIDDLESEX. TW1 4JR		CHK'D		
		APPV'D		
THE INFORMATION IS GIVEN AS AN INDICATION ONLY AND IS SUBJECT TO CHANGE WITHOUT NOTICE. IN THE CONTINUAL GOAL TO IMPROVE OUR PRODUCTS, WE RESERVE THE RIGHT TO MAKE ANY MODIFICATIONS NECESSARY WITHOUT PRIOR NOTICE.				