

SMA 4 HOLE FLANGE JACK SOLDER TAB

30-372-D3

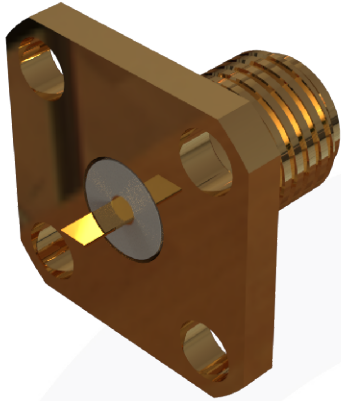

images for illustration purposes only

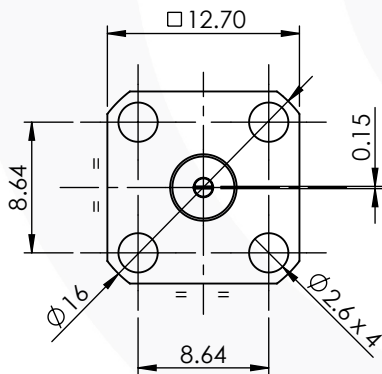
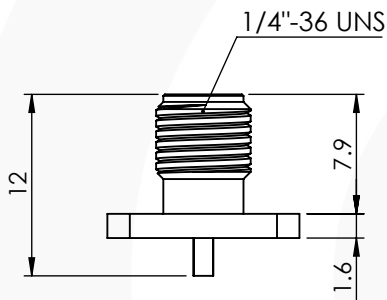

Hole Layout

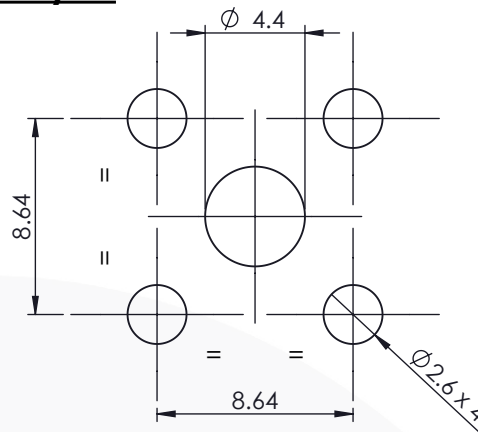

Assembly Procedure:

Tooling

Centre Contact: Solder Tool No: Not Applicable

Crimp Sleeve: Not Applicable Tool No: Not Applicable

Environmental Specification

Operating Temp: -65 to +165 Deg C.

IP Rating (Mated): NONE

Electrical Specification

Impedance: 50 Ohm

Frequency: 0-12 GHz

Dielectric W/V: TBC Veff

Insulation res: 5000 M-Ohm

Mechanical Specification

Contact Retention: 27 N min

Cable Retention: N/A

Mating cycles: 500

Weight: 3.32 g

Connector Interface

image for illustration purposes only

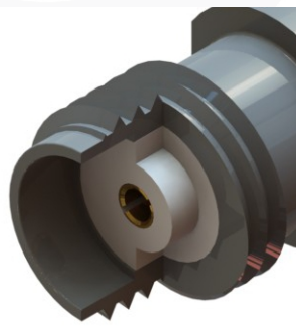

3	INSULATOR	PTFE	N/A
2	CENTRE CONTACT	BeCu	GOLD
1	BODY	BRASS	GOLD
ITEM	DESCRIPTION	MATERIAL	PLATING

A4	SHEET 1 OF 1	DIMENSIONS ARE IN MILLIMETRES		
REVISION :	A00	NAME	SIGNATURE	DATE
ISSUE :	1	DRAWN	S.O'D.	09/11/2016
		CHK'D	G.E.	10/11/2016
		APPV'D		
6-8 COLNE ROAD, TWICKENHAM, MIDDLESEX. TW1 4JR				
THE INFORMATION IS GIVEN AS AN INDICATION ONLY AND IS SUBJECT TO CHANGE WITHOUT NOTICE. IN THE CONTINUAL GOAL TO IMPROVE OUR PRODUCTS, WE RESERVE THE RIGHT TO MAKE ANY MODIFICATIONS NECESSARY WITHOUT PRIOR NOTICE.				