

© 2008. THIS DOCUMENT IS THE PROPERTY OF COAX CONNECTORS LTD. REPRODUCTION OR COMMUNICATION IN ANY FORM TO A THIRD PARTY IS PROHIBITED WITHOUT PRIOR WRITTEN CONSENT

WEBSITE VIDEO No.

DO NOT SCALE DRAWING



Electrical Specification
 Impedance: 50 Ohm
 Frequency: TBC
 Dielectric W/V: TBC
 Insulation res: 5000 M-Ohm

Mechanical Specification
 Centre contact retention
 Axial Force: TBC
 Cable Retention: N/A
 Mating cycles: 100

Environmental Specification
 Operating Temp: -65 to +165 Deg C

Tooling
 Centre Contact: SOLDER
 COAX Tool No:
 Crimp Sleeve: N/A
 COAX Tool No:

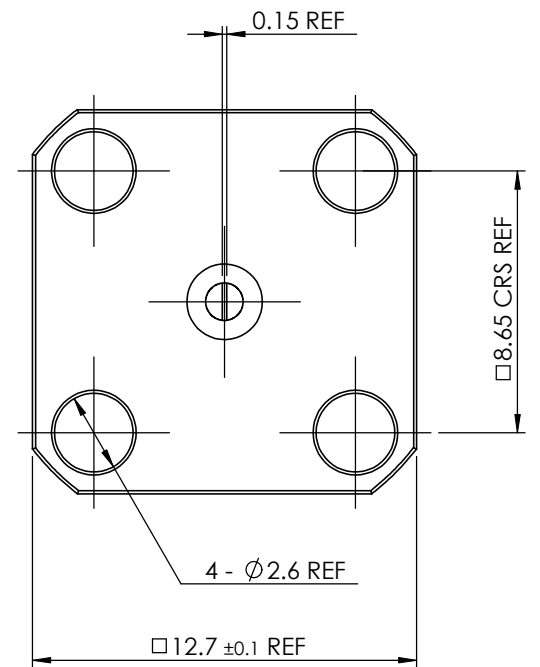
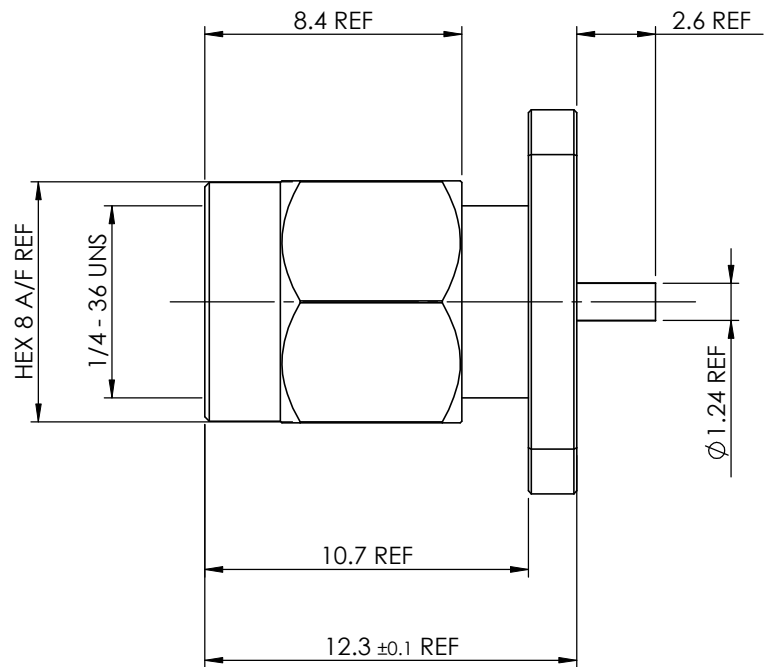

7			
6	CENTRE CONTACT	BRASS	GOLD
5	BODY	BRASS	GOLD
4	RETAINING WASHER	PHOPHOR BRONZE	NICKEL
3	INSULATOR	PTFE	N/A
2	GASKET	SILICONE RUBBER	N/A
1	COUPLING NUT	BRASS	GOLD
ITEM	DESCRIPTION	MATERIAL	PLATING

	COAX CONNECTORS LTD 6-8 COLNE ROAD, TWICKENHAM, MIDDLESEX. TW1 4JR		REVISION A00		A4 <small>DIMENSIONS ARE IN MILLIMETERS</small>	NAME	SIGNATURE	DATE	
	Description	PANEL MOUNT SMA PLUG				DRAWN	GE		26/01/2010
	Part Number	30-323-D3				CHK'D	WF		26/01/2010
	<small>THE INFORMATION IS GIVEN AS AN INDICATION ONLY AND IS SUBJECT TO CHANGE WITHOUT NOTICE. IN THE CONTINUAL GOAL TO IMPROVE OUR PRODUCTS, WE RESERVE THE RIGHT TO MAKE ANY MODIFICATIONS NECESSARY WITHOUT PRIOR NOTICE.</small>								