

N TYPE 4 HOLE FLANGE PLUG WITH SOLDER TAG

25-372-1-B3

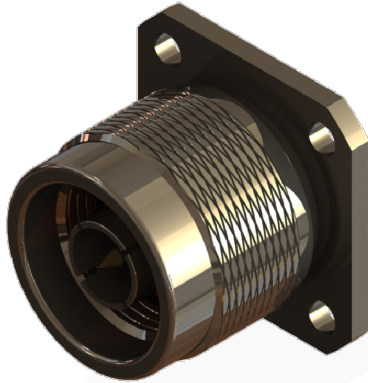

images for illustration purposes only

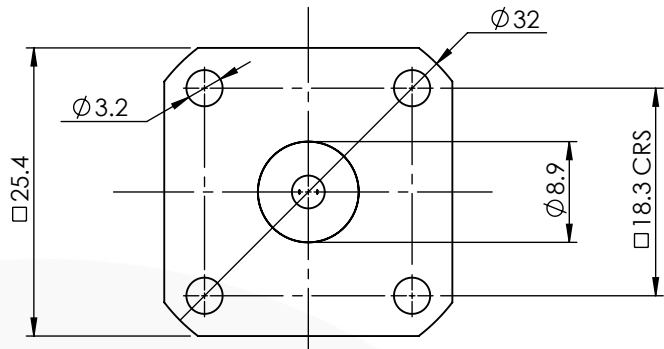

FLANGE MOUNTING HOLES

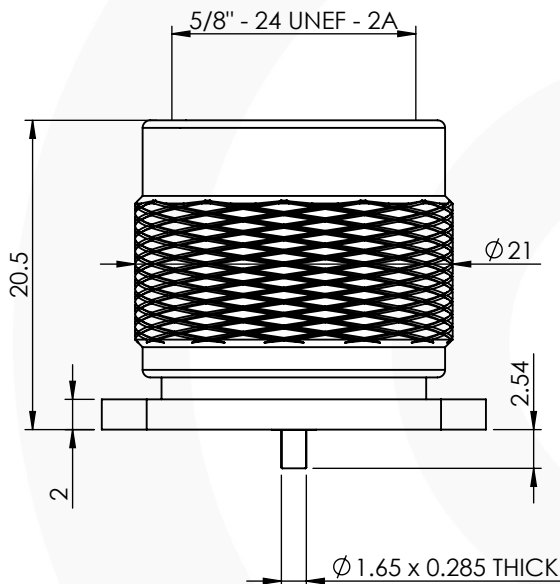

Tooling

Centre Contact: Solder Tool No: Solder
 Crimp Sleeve: Not Applicable Tool No: Not Applicable
 Alignment Tool: Not Applicable Extraction: Not Applicable

Environmental Specification

Operating Temp: -55 to +155 Deg C.
 IP Rating (Mated): NONE

Electrical Specification

Impedance: 50 Ohm
 Frequency: 0 - 11 GHz
 Dielectric W/V: 1000 Veff
 Insulation res: 5000 M-Ohm

Mechanical Specification

Contact Retention: 27 N min
 Cable Retention: N/A
 Mating cycles: 500
 Weight: 29.5 g

Connector Interface

image for illustration purposes only

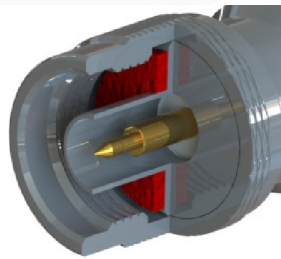

6	GASKET	SILICONE	N/A
5	CONTACT	BRASS	GOLD
4	INSULATORS	PTFE	N/A
3	RETAINING RING	PHOSPHER BRONZE	N/A
2	COUPLING NUT	BRASS	NICKEL
1	BODY	BRASS	NICKEL
ITEM	DESCRIPTION	MATERIAL	PLATING

A4	SHEET 1 OF 1	DIMENSIONS ARE IN MILLIMETRES		
REVISION :	A00	NAME	SIGNATURE	DATE
ISSUE :	1	DRAWN	G.E.	06/08/2021
		CHK'D	P.S.	06/08/2021
		APPV'D		
6-8 COLNE ROAD, TWICKENHAM, MIDDLESEX. TW1 4JR				
THE INFORMATION IS GIVEN AS AN INDICATION ONLY AND IS SUBJECT TO CHANGE WITHOUT NOTICE. IN THE CONTINUAL GOAL TO IMPROVE OUR PRODUCTS, WE RESERVE THE RIGHT TO MAKE ANY MODIFICATIONS NECESSARY WITHOUT PRIOR NOTICE.				