

## N TYPE 4 HOLE 1" SQ. FLANGE MOUNT SOLDER SPILL JACK 25-371-B3

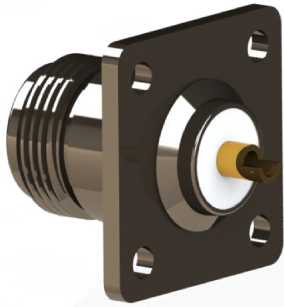

images for illustration purposes only

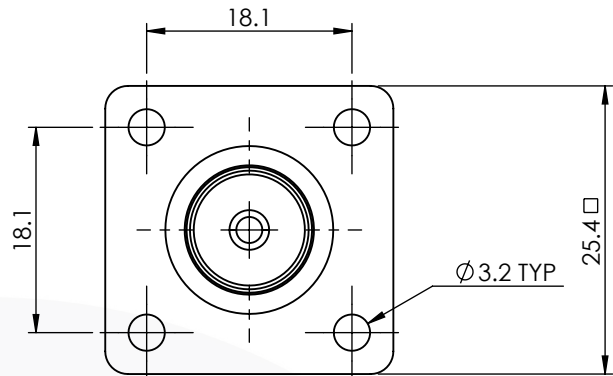
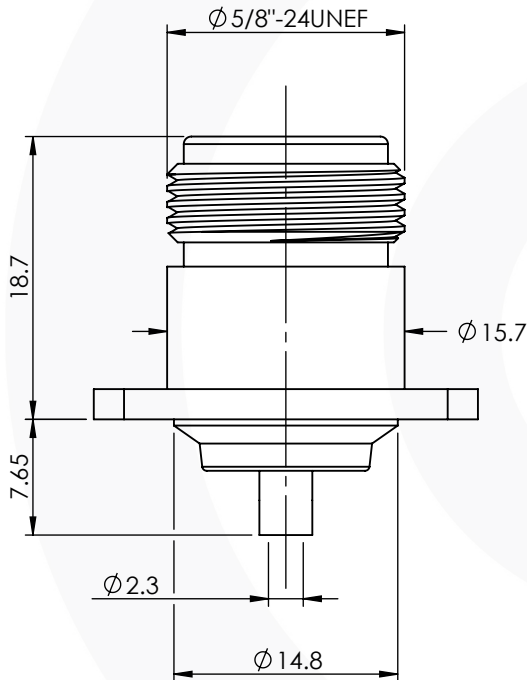

### FLANGE MOUNTING HOLES

#### Tooling

Centre Contact: Solder                      Tool No: Solder  
Crimp Sleeve: Not Applicable              Tool No: Not Applicable  
Alignment Tool: Not Applicable              Extraction: Not Applicable

#### Environmental Specification

Operating Temp: -55 to +155 Deg C.  
IP Rating (Mated): IP 67

#### Electrical Specification

Impedance: 50 Ohm  
Frequency: 0-11 GHz  
Dielectric W/V: 1500 Veff  
Insulation res: 5000 M-Ohm

#### Mechanical Specification

Contact Retention: 27 N min  
Cable Retention: N/A  
Mating cycles: 500  
Weight: 29.5 g

#### Connector Interface

image for illustration purposes only

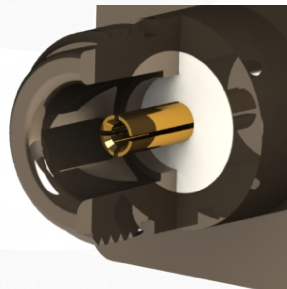

5	CONTACT	PH. BRONZE	GOLD
4	INSULATOR	PTFE	N/A
3	REAR BODY	BRASS	NICKEL
2	FLANGE	BRASS	NICKEL
1	FRONT BODY	BRASS	NICKEL
ITEM	DESCRIPTION	MATERIAL	PLATING

<b>A4</b>	SHEET 1 OF 1	DIMENSIONS ARE IN MILLIMETRES		
REVISION :	A01	NAME	SIGNATURE	DATE
ISSUE :	1	DRAWN	B.S.	08/11/2017
		CHK'D	I.G.	19/01/2018
		APPV'D		
6-8 COLNE ROAD, TWICKENHAM, MIDDLESEX. TW1 4JR THE INFORMATION IS GIVEN AS AN INDICATION ONLY AND IS SUBJECT TO CHANGE WITHOUT NOTICE. IN THE CONTINUAL GOAL TO IMPROVE OUR PRODUCTS, WE RESERVE THE RIGHT TO MAKE ANY MODIFICATIONS NECESSARY WITHOUT PRIOR NOTICE.				