

75 Ohm N TYPE BULKHEAD SOLDER CUP JACK (2 FLATS)

25-350-B6

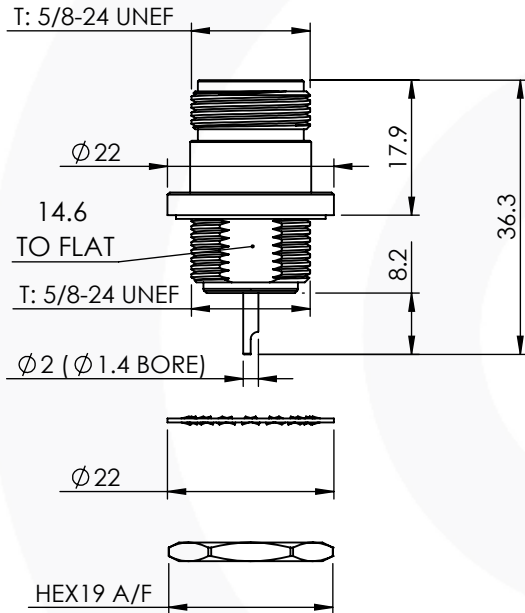

images for illustration purposes only



Recommended Mounting Hole

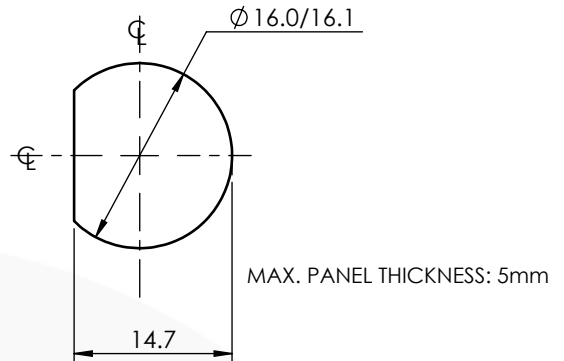

Tooling

Centre Contact: Not Applicable Tool No: Solder
Crimp Sleeve: Not Applicable Tool No: Not Applicable

Environmental Specification

Operating Temp: -55 to +155 Deg C.
IP Rating (Mated): IP 67

Electrical Specification

Impedance: 75 Ohm
Frequency: 0-2 GHz
Dielectric W/V: 2500 Veff
Insulation res: 5000 M-Ohm

Mechanical Specification

Contact Retention: 27 N min
Cable Retention: Not Applicable
Mating cycles: 500
Weight: 35.47 g

Connector Interface

image for illustration purposes only

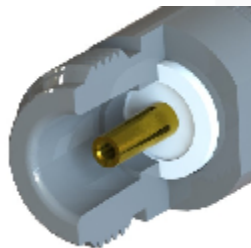

6	WASHER	STAINLESS STEEL	NICKEL
5	GASKET	SILICONE	N/A
4	NUT	BRASS	NICKEL
3	INSULATOR	PTFE	N/A
2	CENTRE CONTACT	PHOS. BRONZE	GOLD
1	BODY	BRASS	NICKEL
ITEM	DESCRIPTION	MATERIAL	PLATING

A4	SHEET 1 OF 1	DIMENSIONS ARE IN MILLIMETRES		
REVISION :	A00	NAME	SIGNATURE	DATE
ISSUE :	1	DRAWN	G.E.	11/04/20
		CHK'D	P.S.	11/04/20
		APPV'D		
6-8 COLNE ROAD, TWICKENHAM, MIDDLESEX. TW1 4JR <small>THE INFORMATION IS GIVEN AS AN INDICATION ONLY AND IS SUBJECT TO CHANGE WITHOUT NOTICE. IN THE CONTINUAL GOAL TO IMPROVE OUR PRODUCTS, WE RESERVE THE RIGHT TO MAKE ANY MODIFICATIONS NECESSARY WITHOUT PRIOR NOTICE.</small>				