

N TYPE CRIMP / CLAMP PLUG

25-290-P3-AW

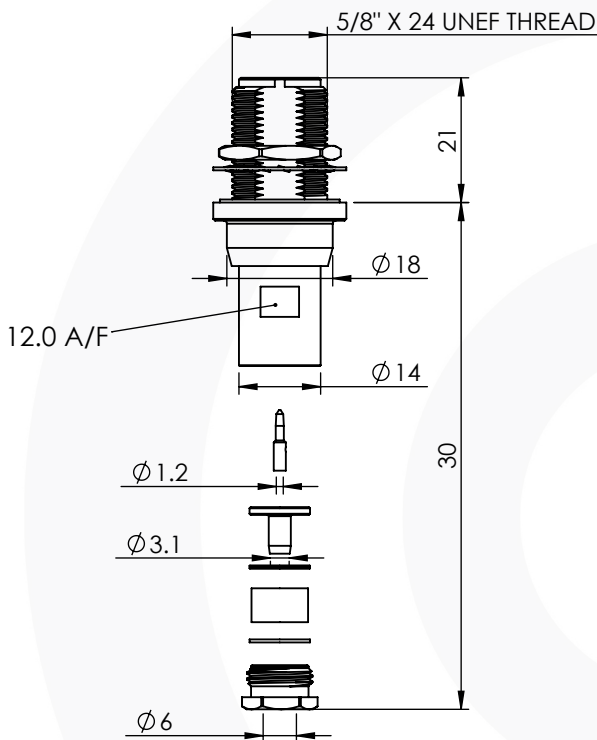
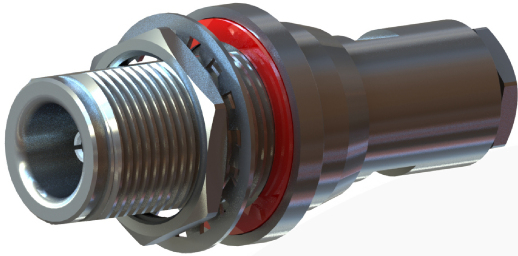

Suitable for Cables:

(AW) Aircell 5

Stripping Dimensions

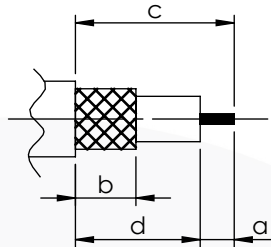

a = 4.0 mm
b = 3.0 mm
c = 6.0 mm
d = 2.0 mm

Assembly Procedure:

Tooling

Centre Contact: Hex 1.72mm A/F Tool No: 96-HTS-75 or 336A

Crimp Sleeve: Not Applicable Tool No: Not Applicable

Alignment Tool: Not Applicable Extraction: Not Applicable

Environmental Specification

Operating Temp: -30 to +70 Deg C.

IP Rating (Unmated): IP 68

Electrical Specification Mechanical Specification

Impedance: 50 Ohm

Contact Retention: 27 N min

Frequency: 0-11 GHz

Cable Retention: 150 N min

Dielectric W/V: 1500 Veff

Mating cycles: 500

Insulation res: 5000 M-Ohm

Weight: 60.47 g

Connector Interface

image for illustration purposes only

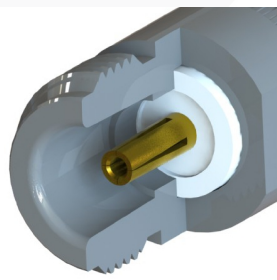

8	FEMALE CONTACT	PHOSPHOR BRONZE	SILVER
7	WASHERS	BRASS	WHITE BRONZE
6	NUT	BRASS	WHITE BRONZE
5	GASKET	SILICONE	N/A
4	REAR BODY	BRASS	WHITE BRONZE
3	INSULATOR	PTFE	N/A
2	BULLET CONTACT	BRASS	SILVER
1	BODY	BRASS	WHITE BRONZE
ITEM	DESCRIPTION	MATERIAL	PLATING

A4	SHEET 1 OF 1	DIMENSIONS ARE IN MILLIMETRES		
REVISION :	A00	NAME	SIGNATURE	DATE
ISSUE :	0	DRAWN	IG	22/11/2017
		CHK'D	GE	23/11/2017
		APPV'D		
6-8 COLNE ROAD, TWICKENHAM, MIDDLESEX. TW1 4JR				
THE INFORMATION IS GIVEN AS AN INDICATION ONLY AND IS SUBJECT TO CHANGE WITHOUT NOTICE. IN THE CONTINUAL GOAL TO IMPROVE OUR PRODUCTS, WE RESERVE THE RIGHT TO MAKE ANY MODIFICATIONS NECESSARY WITHOUT PRIOR NOTICE.				