

N TYPE BULKHEAD EASYFIT/SOLDER JACK 25-267-B3-HA

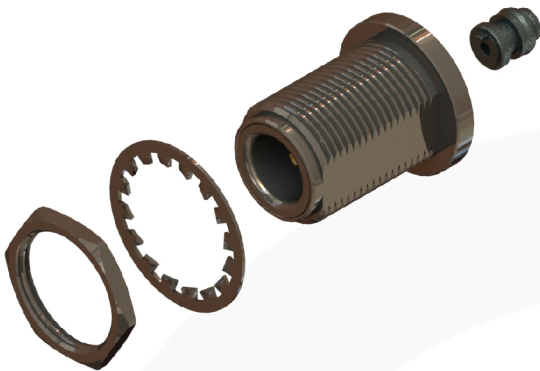

images for illustration purposes only

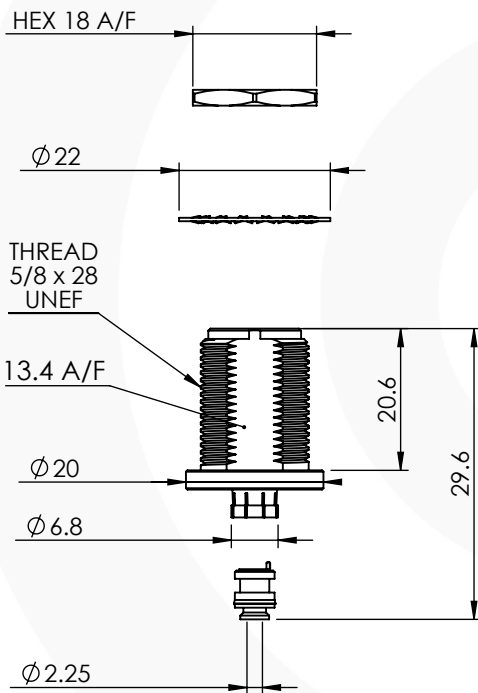

Suitable for Cables:

(HA) RG405 (0.085"), UT85

Stripping Dimensions

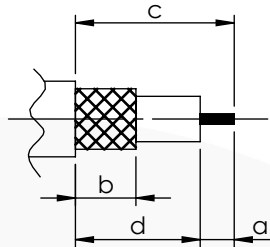

a = 3.3 mm
b = 9.0 mm
c = 12.3 mm
d = 9.0 mm

* CUT FOIL TO DIM. "b"

Assembly Procedure:

Tooling

Centre Contact: Solder Tool No: Not Applicable
Crimp Sleeve: Not Applicable Tool No: Not Applicable
Alignment Tool: Not Applicable Extraction: Not Applicable

Environmental Specification

Operating Temp: -55 to +155 Deg C.
IP Rating (Mated): IP 67

Electrical Specification

Impedance: 50 Ohm
Frequency: 0-10 GHz
Dielectric W/V: 1500 Veff
Insulation res: 5000 M-Ohm

Mechanical Specification

Contact Retention: 10 N min
Cable Retention: 150 N min
Mating cycles: 500
Weight: 34.89 g

Connector Interface

image for illustration purposes only

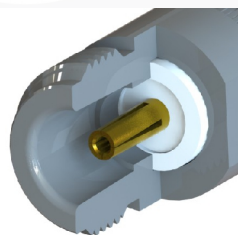

Recommended Mounting

MAXIMUM PANEL THICKNESS : 7.5mm

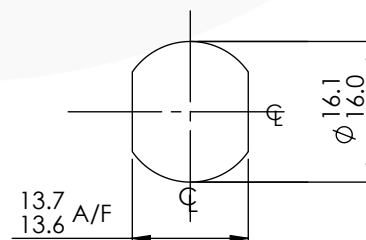

5	GASKET	SILICONE RUBBER	N/A
4	SOLDER FERRULE	BRASS	TIN
3	INSULATORS	PTFE	N/A
2	CENTRE CONTACT	BERYLLIUM COPPER	GOLD
1	BODY & NUT	BRASS	NICKEL
ITEM	DESCRIPTION	MATERIAL	PLATING
A4	SHEET 1 OF 1	DIMENSIONS ARE IN MILLIMETRES	
REVISION :	A00	NAME	SIGNATURE
ISSUE :	1	DATE	
		DRAWN	G.E.
		CHK'D	I.G.
		APPV'D	
<p>6-8 COLNE ROAD, TWICKENHAM, MIDDLESEX. TW1 4JR</p> <p>THE INFORMATION IS GIVEN AS AN INDICATION ONLY AND IS SUBJECT TO CHANGE WITHOUT NOTICE. IN THE CONTINUAL GOAL TO IMPROVE OUR PRODUCTS, WE RESERVE THE RIGHT TO MAKE ANY MODIFICATIONS NECESSARY WITHOUT PRIOR NOTICE.</p>			