

## N TYPE B/H SOLDER / SOLDER JACK 25-267-2-B3-HA

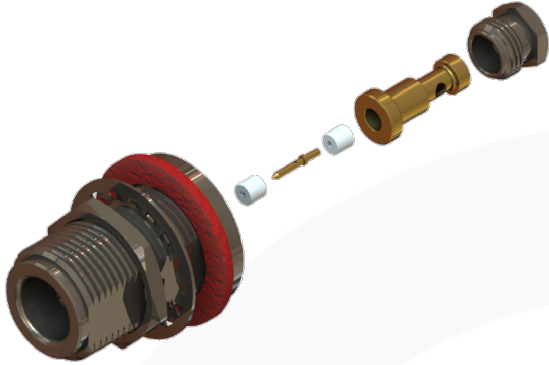

images for illustration purposes only

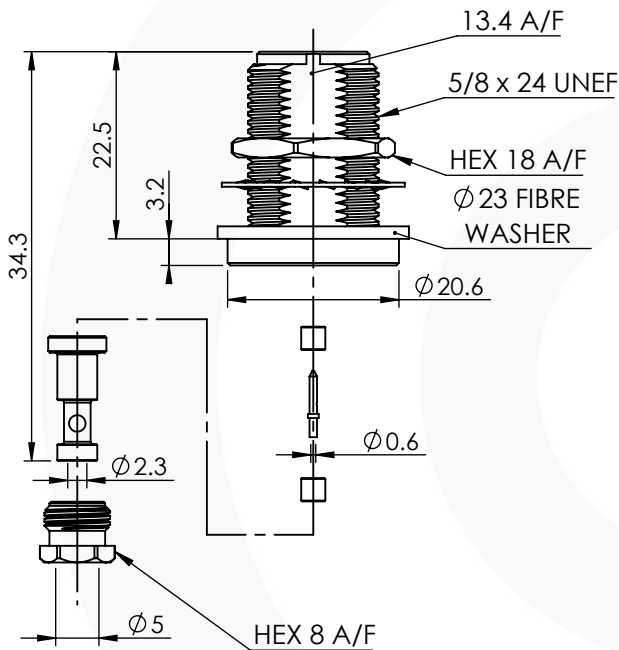

### Suitable for Cables:

(HA) RG405 (0.085"), UT85

### Stripping Dimensions

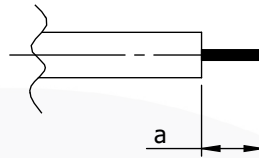

a = 5.0 mm

### RECOMMENDED MOUNTING:

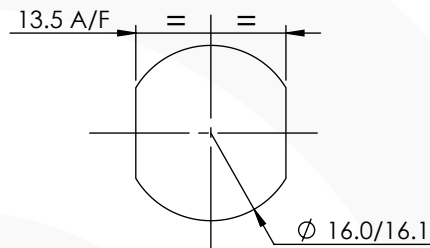

### Environmental Specification

Operating Temp: -65 to +155 Deg C.

IP Rating (Mated): IP 67

### Electrical Specification

Impedance: 50 Ohm

Frequency: 0-18 GHz

Dielectric W/V: 1500 Veff

Insulation res: 5000 M-Ohm

### Mechanical Specification

Contact Retention: 27 N min

Cable Retention: 150 N min

Mating cycles: 500

Weight: 40.10 g

### Connector Interface

image for illustration purposes only

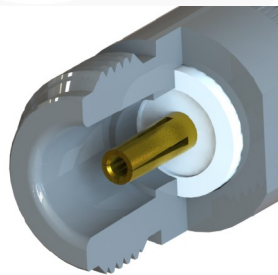

| 8    | FIBRE WASHER   | RED FIBRE        | N/A        |
|------|----------------|------------------|------------|
| 7    | LOCK WASHER    | STAINLESS STEEL  | PASSIVATED |
| 6    | NUT            | BRASS            | NICKEL     |
| 5    | CLAMP NUT      | BRASS            | NICKEL     |
| 4    | SOLDER SLEEVE  | BRASS            | GOLD       |
| 3    | INSULATORS     | PTFE             | N/A        |
| 2    | CENTRE CONTACT | BERYLLIUM COPPER | GOLD       |
| 1    | BODY           | BRASS            | NICKEL     |
| ITEM | DESCRIPTION    | MATERIAL         | PLATING    |

|   |              |                               |           |            |
|---|--------------|-------------------------------|-----------|------------|
| <b>A4</b>   | SHEET 1 OF 1 | DIMENSIONS ARE IN MILLIMETRES |           |            |
| REVISION :  | B00          | NAME                          | SIGNATURE | DATE       |
| ISSUE :   | 1            | DRAWN                         | G.E.      | 27/11/2020 |
|   |              | CHK'D                         | P.S.      | 27/11/2020 |
|   |              | APPV'D                        |           |            |
| 6-8 COLNE ROAD,<br>TWICKENHAM,<br>MIDDLESEX.<br>TW1 4JR   |              |                               |           |            |
| THE INFORMATION IS GIVEN AS AN INDICATION ONLY AND IS SUBJECT TO CHANGE WITHOUT NOTICE. IN THE CONTINUAL GOAL TO IMPROVE OUR PRODUCTS, WE RESERVE THE RIGHT TO MAKE ANY MODIFICATIONS NECESSARY WITHOUT PRIOR NOTICE. |              |                               |           |            |