

N TYPE BULKHEAD CRIMP / CRIMP JACK 25-255-B3-AK

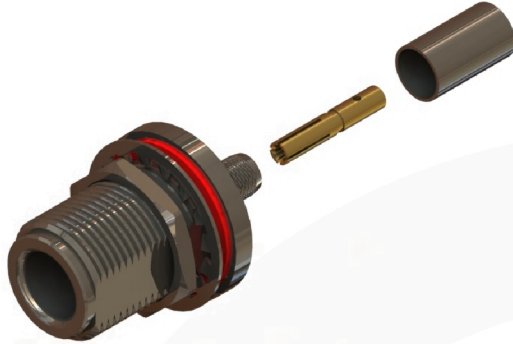

images for illustration purposes only

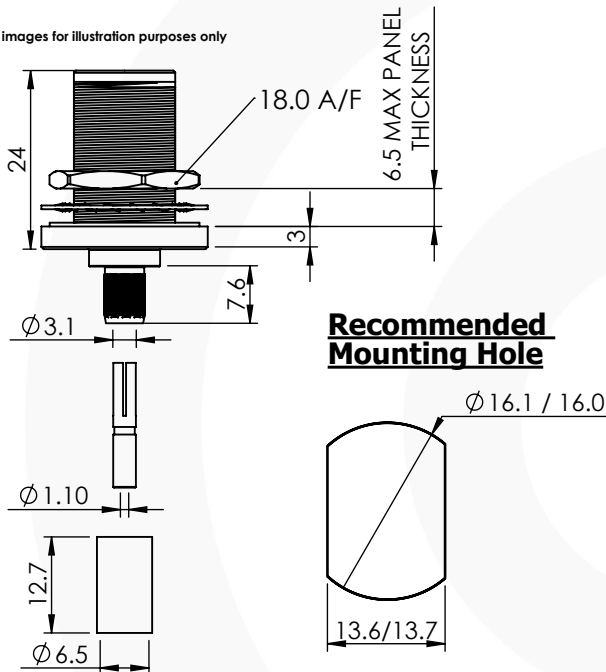

Recommended Mounting Hole

Suitable for Cables:

RG223

Stripping Dimensions

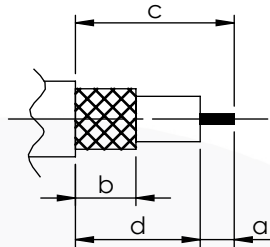

- a = 4.0 mm
- b = 8.0 mm
- c = 14.5 mm
- d = 10.5 mm

* CUT FOIL TO DIM. "b"

Assembly Procedure: AP001

Tooling

Centre Contact: Hex 2.54mm A/F Tool No: 336G

Crimp Sleeve: Hex 6.50mm A/F Tool No: 336A

Alignment Tool:

Extraction:

Environmental Specification

Operating Temp: -55 to +155 Deg C.

IP Rating (Mated): IP65

Electrical Specification

Impedance: 50 Ohm

Frequency: 0-10 GHz

Dielectric W/V: 1500 Veff

Insulation res: 5000 M-Ohm

Mechanical Specification

Contact Retention: 10 N min

Cable Retention: 220 N min

Mating cycles: 250

Weight: 35.27 g

Connector Interface

image for illustration purposes only

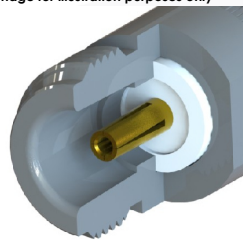

8	NUT	BRASS	NICKEL
7	SPRING WASHER	PHOS. BRONZE	NICKEL
6	REAR BODY	BRASS	NICKEL
5	GASKET	SILICONE	N/A
4	CRIMP SLEEVE	BRASS	NICKEL
3	INSULATOR	PTFE	N/A
2	CENTRE CONTACT	PHOS. BRONZE	GOLD
1	BODY	BRASS	NICKEL
ITEM	DESCRIPTION	MATERIAL	PLATING

A4	SHEET 1 OF 1	DIMENSIONS ARE IN MILLIMETRES		
REVISION :	B00	NAME	SIGNATURE	DATE
ISSUE :	1	DRAWN	IG	18/04/2012
		CHK'D	GE	25/04/2012
		APPV'D		
6-8 COLNE ROAD, TWICKENHAM, MIDDLESEX. TW1 4JR				
THE INFORMATION IS GIVEN AS AN INDICATION ONLY AND IS SUBJECT TO CHANGE WITHOUT NOTICE. IN THE CONTINUAL GOAL TO IMPROVE OUR PRODUCTS, WE RESERVE THE RIGHT TO MAKE ANY MODIFICATIONS NECESSARY WITHOUT PRIOR NOTICE.				