

## N TYPE BULKHEAD SOLDER JACK 25-217-H3-HB

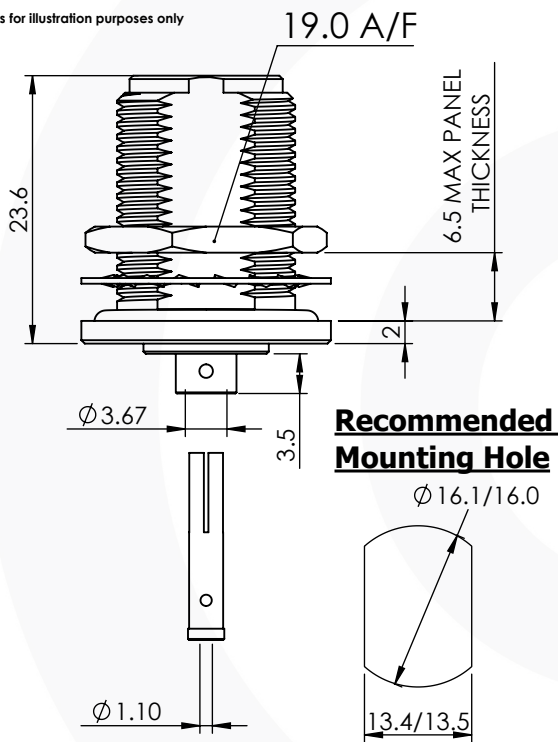

images for illustration purposes only



### Suitable for Cables:

(HB) RG402 (0.141"), UT141

### Stripping Dimensions

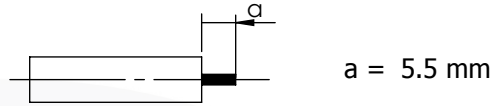

### Assembly Procedure: AP033

### Tooling

Centre Contact: Solder

Tool No: Not Applicable

Crimp Sleeve: Solder

Tool No: Not Applicable

### Environmental Specification

Operating Temp: -55 to +155 Deg C.

IP Rating (Mated):

### Electrical Specification

Impedance: 50 Ohm

Frequency: 0-18 GHz

Dielectric W/V: 1500 Veff

Insulation res: 5000 M-Ohm

### Mechanical Specification

Contact Retention: 10 N min

Cable Retention: 220 N min

Mating cycles: 500

Weight: 32.34 g

### Connector Interface

image for illustration purposes only

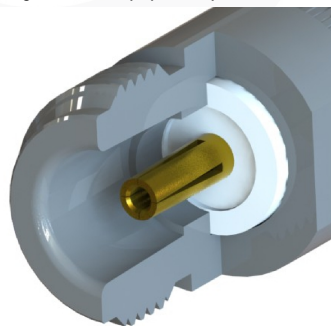

ITEM	DESCRIPTION	MATERIAL	PLATING
6	NUT/WASHER	STAINLESS STEEL	PASSIVATED
5	OUTER BODY	STAINLESS STEEL	PASSIVATED
4	GASKET	SILICONE	N/A
3	INSULATOR	PTFE	N/A
2	CENTRE CONTACT	BERYLLIUM COPPER	GOLD
1	BODY	STAINLESS STEEL	GOLD

<b>A4</b>	SHEET 1 OF 1	DIMENSIONS ARE IN MILLIMETRES		
REVISION :	A00	NAME	SIGNATURE	DATE
ISSUE :	0	DRAWN	S.O'D.	21/06/2016
		CHK'D	I.G.	21/06/2016
		APPV'D		
6-8 COLNE ROAD, TWICKENHAM, MIDDLESEX. TW1 4JR				
THE INFORMATION IS GIVEN AS AN INDICATION ONLY AND IS SUBJECT TO CHANGE WITHOUT NOTICE. IN THE CONTINUAL GOAL TO IMPROVE OUR PRODUCTS, WE RESERVE THE RIGHT TO MAKE ANY MODIFICATIONS NECESSARY WITHOUT PRIOR NOTICE.				