

## N TYPE STRAIGHT EASIFIT / CRIMP JACK

### 25-068-B3-DE

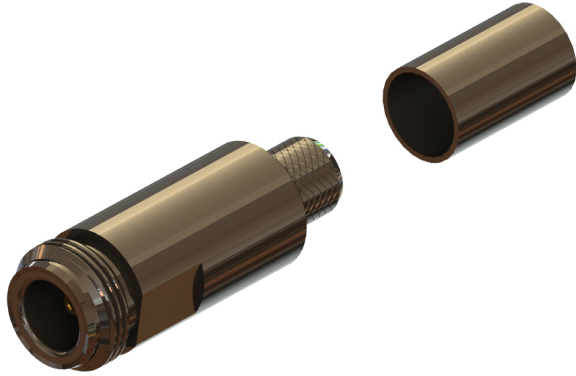

images for illustration purposes only

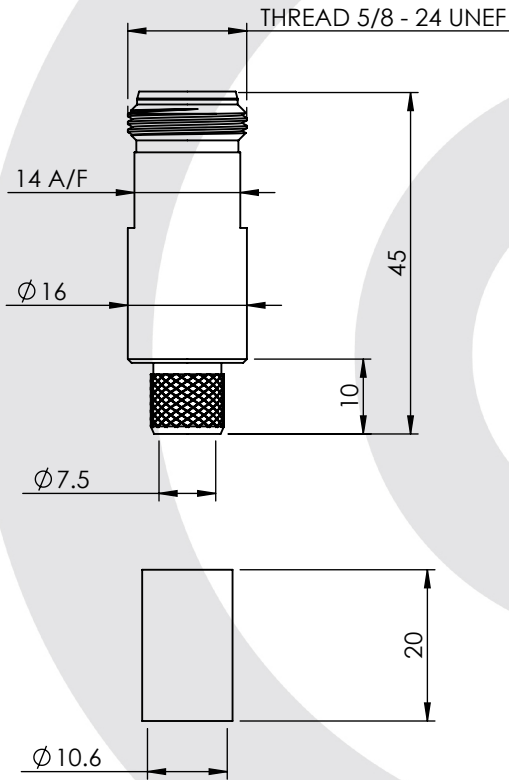

### Suitable for Cables:

(DE) LMR400, TZC50032, Belden 9913, RG8

### Stripping Dimensions

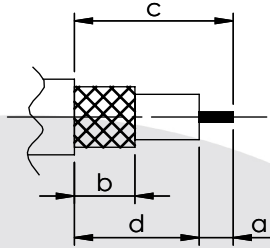

a = 5.0 mm  
b = 10.0 mm  
c = 18.0 mm  
d = 13.0 mm

\* CUT FOIL TO DIM. "b"

### Assembly Procedure:

#### Tooling

Centre Contact: N/A

Tool No: N/A

Crimp Sleeve: HEX 10.9mm A/F

Tool No: 336K

Alignment Tool: Not Applicable

Extraction: Not Applicable

### Environmental Specification

Operating Temp: -55 to +155 Deg C.

IP Rating (Mated): IP 65

### Electrical Specification

Impedance: 50 Ohm

Frequency: 0-11 GHz

Dielectric W/V: 2500 Veff

Insulation res: 5000 M-Ohm

### Mechanical Specification

Contact Retention: 27 N min

Cable Retention: 200N min N min

Mating cycles: 250

Weight: 45.70 g

### Connector Interface

image for illustration purposes only

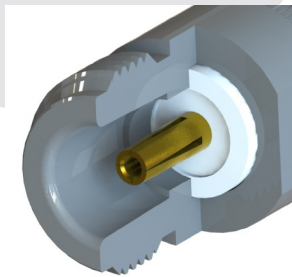

4	CRIMP SLEEVE	BRASS	NICKEL
3	INSULATOR	PTFE	N/A
2	CENTRE CONTACT	BeCu	GOLD
1	BODY	BRASS	NICKEL
ITEM	DESCRIPTION	MATERIAL	PLATING

<b>A4</b>	SHEET 1 OF 1	DIMENSIONS ARE IN MILLIMETRES		
REVISION :	A03	NAME	SIGNATURE	DATE
ISSUE :	1	DRAWN	IG	15/06/2010
		CHK'D	GE	03/07/2010
		APPV'D		
6-8 COLNE ROAD, TWICKENHAM, MIDDLESEX. TW1 4JR				
THE INFORMATION IS GIVEN AS AN INDICATION ONLY AND IS SUBJECT TO CHANGE WITHOUT NOTICE. IN THE CONTINUAL GOAL TO IMPROVE OUR PRODUCTS, WE RESERVE THE RIGHT TO MAKE ANY MODIFICATIONS NECESSARY WITHOUT PRIOR NOTICE.				