

F TYPE STRAIGHT CRIMP / CRIMP PLUG 15-005-B36-FE

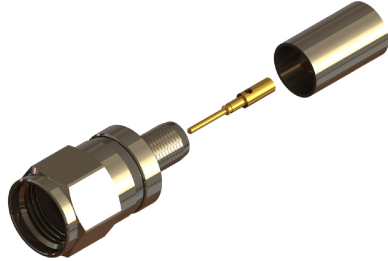

images for illustration purposes only

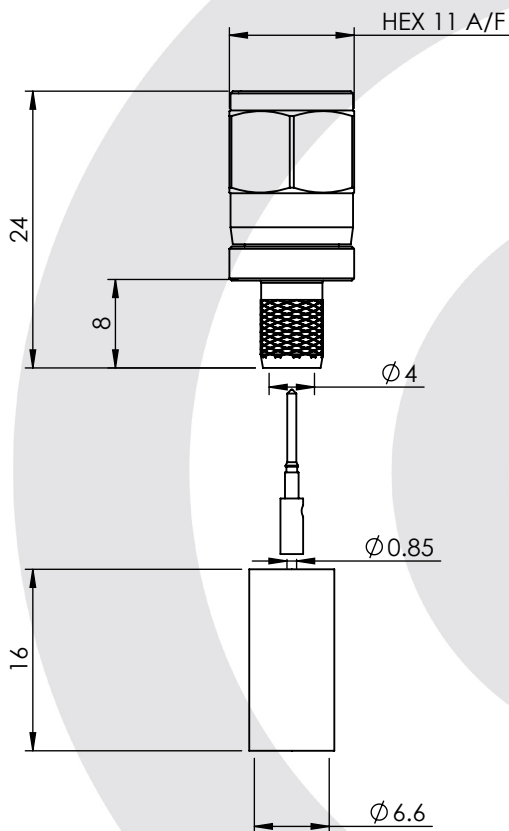

Suitable for Cables:

(FE) Belden 1505F, Bryant BD SD50F

Stripping Dimensions

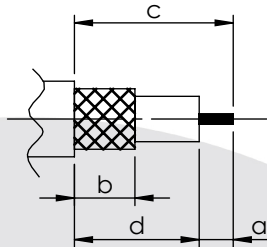

a = 4.0 mm
b = 8.0 mm
c = 16.0 mm
d = 12.0 mm

* CUT FOIL TO DIM. "b"

Assembly Procedure: AP001

Tooling

Centre Contact: Hex 1.72mm A/F Tool No: 96-HTS-76

Crimp Sleeve: HEX 6.48mm A/F Tool No: 96-HTS-76

Alignment Tool:

Extraction:

Environmental Specification

Operating Temp: -55 to +155 Deg C.

IP Rating (Mated): IP 64

Electrical Specification

Impedance: 75 Ohm

Frequency: 0-3 GHz

Dielectric W/V: 1500 Veff

Insulation res: 5000 M-Ohm

Mechanical Specification

Contact Retention: 10 N min

Cable Retention: 150 N min

Mating cycles: 250

Weight: 8.58 g

Connector Interface

image for illustration purposes only

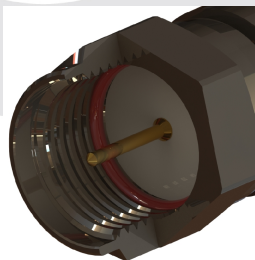

5	COUPLING NUT	BRASS	NICKEL
4	CRIMP SLEEVE	BRASS	NICKEL
3	INSULATOR	PTFE	N/A
2	CENTRE CONTACT	BRASS	GOLD
1	BODY	BRASS	NICKEL
ITEM	DESCRIPTION	MATERIAL	PLATING

A4	SHEET 1 OF 1	DIMENSIONS ARE IN MILLIMETRES		
REVISION :	C00	NAME	SIGNATURE	DATE
ISSUE :	1	DRAWN	IG	26/11/2014
		CHK'D	GE	27/11/2014
		APPV'D		
6-8 COLNE ROAD, TWICKENHAM, MIDDLESEX. TW1 4JR				
THE INFORMATION IS GIVEN AS AN INDICATION ONLY AND IS SUBJECT TO CHANGE WITHOUT NOTICE. IN THE CONTINUAL GOAL TO IMPROVE OUR PRODUCTS, WE RESERVE THE RIGHT TO MAKE ANY MODIFICATIONS NECESSARY WITHOUT PRIOR NOTICE.				