

## F TYPE STRAIGHT CRIMP / CRIMP PLUG

### 15-005-B36-FA

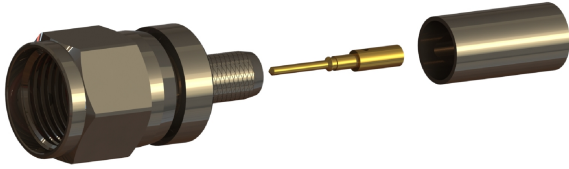

#### Suitable for Cables:

(FA) Belden 1855ENH, Draka 0.6/2.8AF, Bryant BD SD01, Image 360, Percon VK5, Condufil 9890

#### Stripping Dimensions

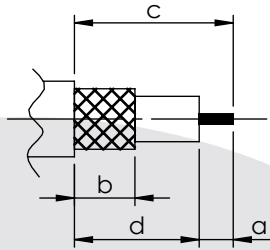

- a = 4.0 mm
- b = 8.0 mm
- c = 16.0 mm
- d = 12.0 mm

\* CUT FOIL TO DIM. "b"

#### Assembly Procedure: AP001

#### Tooling

Centre Contact: Hex 1.72mm A/F Tool No: 336A

Crimp Sleeve: Hex 6.50mm A/F Tool No: 336A

Alignment Tool:

Extraction:

#### Environmental Specification

Operating Temp: -55 to +155 Deg C.

IP Rating (Mated): IP 64

#### Electrical Specification

Impedance: 75 Ohm

Frequency: 0-3 GHz

Dielectric W/V: 1500 Veff

Insulation res: 5000 M-Ohm

#### Mechanical Specification

Contact Retention: 10 N min

Cable Retention: 150 N min

Mating cycles: 250

Weight: g

#### Connector Interface

image for illustration purposes only

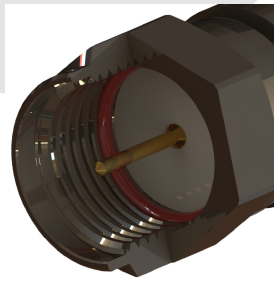

images for illustration purposes only

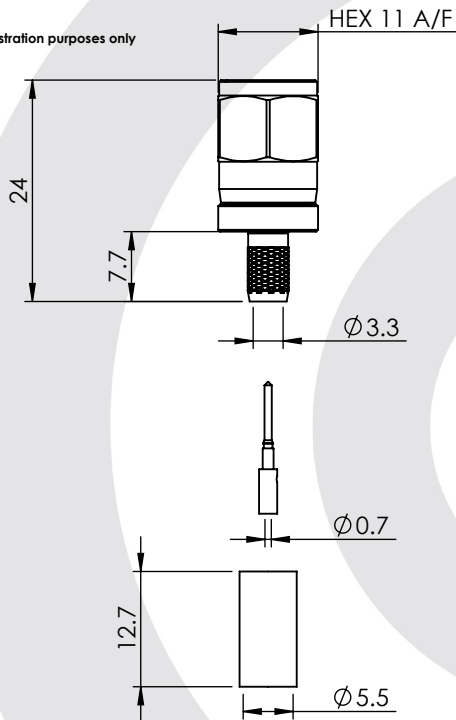

6	COUPLING NUT	BRASS	NICKEL
5	GASKET	SILICONE	N/A
4	CRIMP SLEEVE	BRASS	NICKEL
3	INSULATOR	PTFE	N/A
2	CENTRE CONTACT	BRASS	GOLD
1	BODY	BRASS	NICKEL
ITEM	DESCRIPTION	MATERIAL	PLATING

<b>A4</b>	SHEET 1 OF 1	DIMENSIONS ARE IN MILLIMETRES		
REVISION :	B01	NAME	SIGNATURE	DATE
DRAWN	IG			02/03/2015
ISSUE :	1	CHK'D	GE	03/03/2015
6-8 COLNE ROAD, TWICKENHAM, MIDDLESEX. TW1 4JR		APPV'D		
THE INFORMATION IS GIVEN AS AN INDICATION ONLY AND IS SUBJECT TO CHANGE WITHOUT NOTICE. IN THE CONTINUAL GOAL TO IMPROVE OUR PRODUCTS, WE RESERVE THE RIGHT TO MAKE ANY MODIFICATIONS NECESSARY WITHOUT PRIOR NOTICE.				