

## F TYPE STRAIGHT CRIMP/CRIMP PLUG 15-005-B36-1-FE

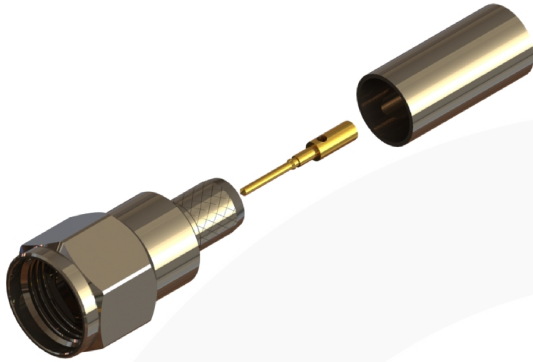

images for illustration purposes only

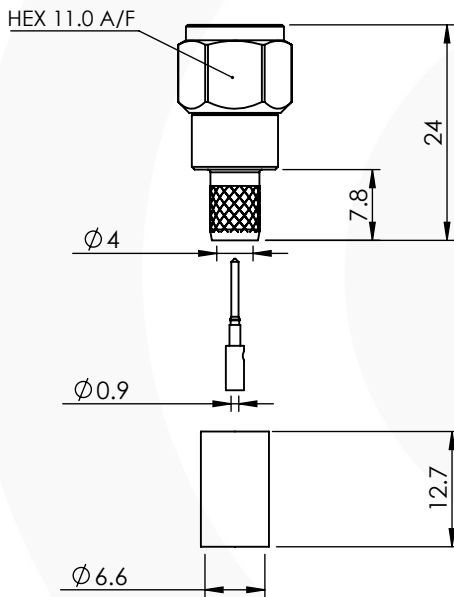

### Suitable for Cables:

(FE) Belden 1505F, Bryant BD SD50F

### Stripping Dimensions

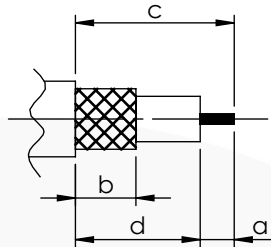

- a = 4.0 mm
- b = 8.0 mm
- c = 13.5 mm
- d = 9.5 mm

\* CUT FOIL TO DIM. "b"

### Assembly Procedure:

#### Tooling

Centre Contact: Hex 1.72mm A/F Tool No: 96-HTS-76

Crimp Sleeve: HEX 6.48mm A/F Tool No: 96-HTS-76

Alignment Tool: Not Applicable Extraction: Not Applicable

### Environmental Specification

Operating Temp: -55 to +155 Deg C.

IP Rating (Mated): IP 64

### Electrical Specification

Impedance: 75 Ohm

Frequency: 0-3 GHz

Dielectric W/V: 1500 Veff

Insulation res: 5000 M-Ohm

### Mechanical Specification

Contact Retention: 10 N min

Cable Retention: 150 N min

Mating cycles: 250

Weight: 7.42 g

### Connector Interface

image for illustration purposes only

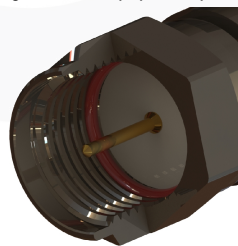

| 5    | COUPLING NUT   | BRASS    | NICKEL  |
|------|----------------|----------|---------|
| 4    | CRIMP SLEEVE   | BRASS    | NICKEL  |
| 3    | INSULATOR      | PTFE     | N/A     |
| 2    | CENTRE CONTACT | BRASS    | GOLD    |
| 1    | BODY           | BRASS    | NICKEL  |
| ITEM | DESCRIPTION    | MATERIAL | PLATING |

|   |              |                               |           |          |
|---|--------------|-------------------------------|-----------|----------|
| <b>A4</b>   | SHEET 1 OF 1 | DIMENSIONS ARE IN MILLIMETRES |           |          |
| REVISION :  | A00          | NAME                          | SIGNATURE | DATE     |
| ISSUE :   | 1            | DRAWN                         | G.E.      | 31/05/17 |
|   |              | CHK'D                         | I.G.      | 31/05/17 |
|   |              | APPV'D                        |           |          |
| 6-8 COLNE ROAD,<br>TWICKENHAM,<br>MIDDLESEX.<br>TW1 4JR   |              |                               |           |          |
| THE INFORMATION IS GIVEN AS AN INDICATION ONLY AND IS SUBJECT TO CHANGE WITHOUT NOTICE. IN THE CONTINUAL GOAL TO IMPROVE OUR PRODUCTS, WE RESERVE THE RIGHT TO MAKE ANY MODIFICATIONS NECESSARY WITHOUT PRIOR NOTICE. |              |                               |           |          |