

## BNC INSULATED BULKHEAD CRIMP / CRIMP JACK

### 10-258-D126-FB1

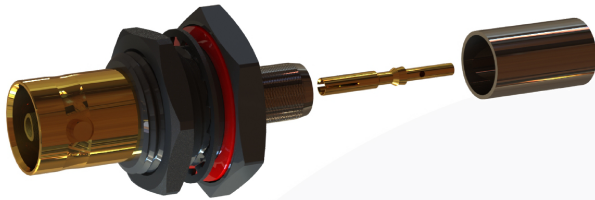

images for illustration purposes only

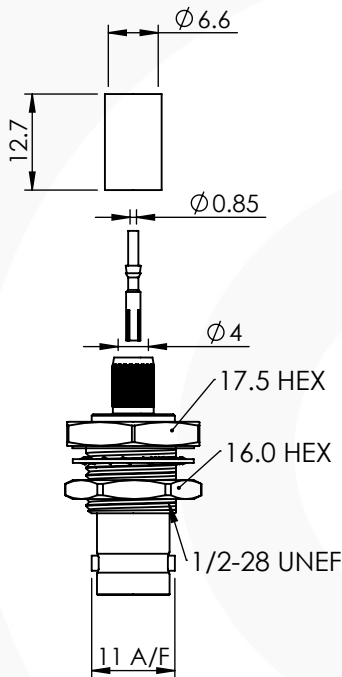

### Recommended Mounting Hole

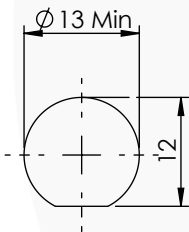

### Suitable for Cables:

(FB) Belden 1505A, Draka 0.8/3.7 A/F, Image 720, Bryant BD SD50A, Percon VK6, Condufil 14472,

### Stripping Dimensions

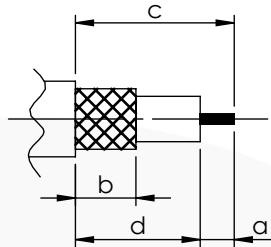

a = 4.0 mm  
b = 7.5 mm  
c = 16.0 mm  
d = 12.0 mm

\* CUT FOIL TO DIM. "b"

### Assembly Procedure: AP001

### Tooling

Centre Contact: Indent or SQ 1.07mm A/F Tool No: 96-HTS-77

Crimp Sleeve: HEX 6.48mm A/F Tool No: 96-HTS-77

Alignment Tool: N/A

Extraction: N/A

### Environmental Specification

Operating Temp: -55 to +155 Deg C.

IP Rating (Mated): IP 64

### Electrical Specification

Impedance: 75 Ohm

Frequency: 0-12.0 GHz

Dielectric W/V: 1500 Veff

Insulation res: 5000 M-Ohm

### Mechanical Specification

Contact Retention: 10 N min

Cable Retention: 150 N min

Mating cycles: 500

Weight: 14.10 g

### Connector Interface

image for illustration purposes only

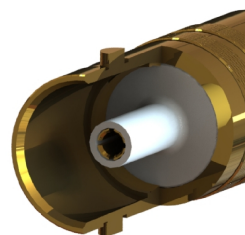

8	NUT	BRASS	NICKEL
7	WASHERS	SK5	NICKEL
6	OVER MOULDING	ABS	N/A
5	GASKET	SILICONE	N/A
4	CRIMP SLEEVE	BRASS	NICKEL
3	INSULATOR	PTFE	N/A
2	CENTRE CONTACT	PHOS. BRONZE	GOLD
1	BODY	BRASS	GOLD
ITEM	DESCRIPTION	MATERIAL	PLATING

<b>A4</b>	SHEET 1 OF 1	DIMENSIONS ARE IN MILLIMETRES		
REVISION :	A01	NAME	SIGNATURE	DATE
ISSUE :	1	DRAWN	IG	26/10/2018
		CHK'D	GE	27/10/2018
		APPV'D		
6-8 COLNE ROAD, TWICKENHAM, MIDDLESEX. TW1 4JR				
THE INFORMATION IS GIVEN AS AN INDICATION ONLY AND IS SUBJECT TO CHANGE WITHOUT NOTICE. IN THE CONTINUAL GOAL TO IMPROVE OUR PRODUCTS, WE RESERVE THE RIGHT TO MAKE ANY MODIFICATIONS NECESSARY WITHOUT PRIOR NOTICE.				