

## BNC STRAIGHT INSULATED BULKHEAD CRIMP / CRIMP JACK

### 10-258-B36-EF

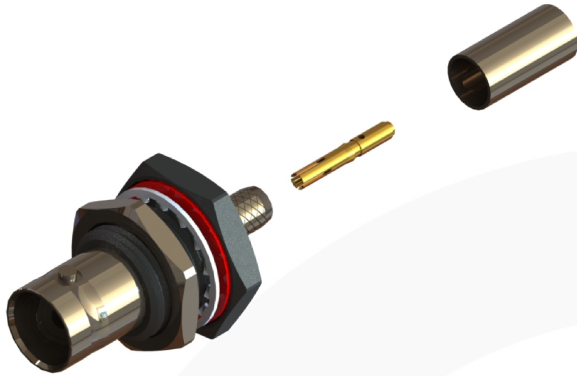

images for illustration purposes only

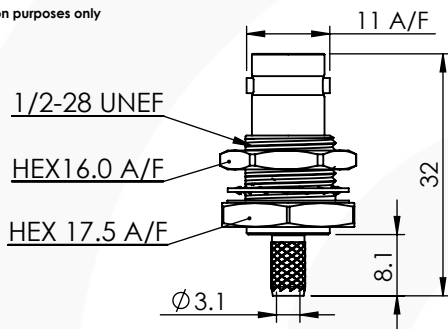

### Recommended Mounting Hole

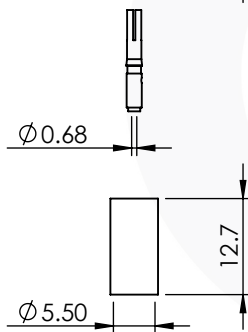
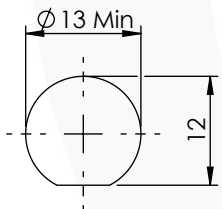

### Suitable for Cables:

(EF) Belden 1855A

### Stripping Dimensions

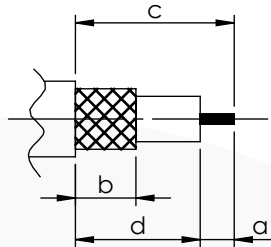

- a = 4.0 mm
- b = 8.0 mm
- c = 19.0 mm
- d = 15.0 mm

\* CUT FOIL TO DIM. "b"

### Assembly Procedure: AP001

### Tooling

Centre Contact: Hex 1.72mm A/F Tool No: 96-HTS-75A

Crimp Sleeve: Hex 5.41mm A/F Tool No: 96-HTS-75A

Alignment Tool: N/A Extraction: N/A

### Environmental Specification

Operating Temp: -55 to +155 Deg C.

IP Rating (Mated): IP 64

### Electrical Specification

Impedance: 75 Ohm

Frequency: 0-4.5 GHz

Dielectric W/V: 1500 Veff

Insulation res: 5000 M-Ohm

### Mechanical Specification

Contact Retention: 10 N min

Cable Retention: 150 N min

Mating cycles: 500

Weight: 13.05 g

### Connector Interface

image for illustration purposes only

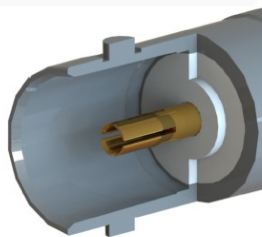

8	NUT	BRASS	NICKEL
7	WASHERS	BRASS	NICKEL
6	OVER MOULDING	ABS	N/A
5	GASKET	SILICONE	N/A
4	CRIMP SLEEVE	BRASS	NICKEL
3	INSULATOR	PTFE	N/A
2	CENTRE CONTACT	PHOS. BRONZE	GOLD
1	BODY	BRASS	NICKEL
ITEM	DESCRIPTION	MATERIAL	PLATING

<b>A4</b>	SHEET 1 OF 1	DIMENSIONS ARE IN MILLIMETRES		
REVISION :	A00	NAME	SIGNATURE	DATE
ISSUE :	2	DRAWN	IG	26/09/13
		CHK'D	GE	27/09/13
		APPV'D		
6-8 COLNE ROAD, TWICKENHAM, MIDDLESEX. TW1 4JR				
THE INFORMATION IS GIVEN AS AN INDICATION ONLY AND IS SUBJECT TO CHANGE WITHOUT NOTICE. IN THE CONTINUAL GOAL TO IMPROVE OUR PRODUCTS, WE RESERVE THE RIGHT TO MAKE ANY MODIFICATIONS NECESSARY WITHOUT PRIOR NOTICE.				