



BNC STR. CR. PLUG IMAGE 360 (3 GHz) 10-005-T36-FA

Suitable for Cables:

IMAGE 360

Electrical Specification

Impedance:	75 Ohm
Frequency:	0 - 3 GHz (Cable Limited)
Dielectric W/V:	1500 Veff
Insulation res:	5000 M-Ohm

Mechanical Specification

Centre contact retention	
Axial Force:	10 N min
Cable Retention:	100 N min
Mating cycles:	500
Weight:	9.74 g

Environmental Specification

Operating Temp:	-55 to +155 Deg C.
-----------------	--------------------

Tooling

Centre Contact:	HEX 1.72 A/F
Tool No:	336A
Crimp Sleeve:	HEX 5.41 A/F
Tool No:	336A

DO NOT SCALE DRAWING

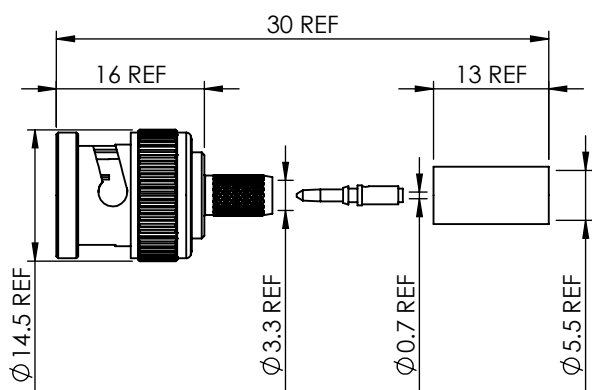

Assembly Procedure : AP001

The assembly procedure is given on its own separate instruction sheet.
Please request the above AP number.

Stripping Dimensions

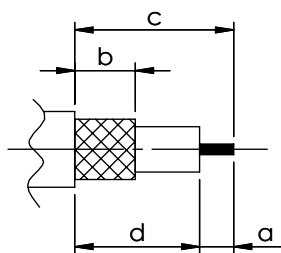

a =	4.0 mm
b =	8.0 mm
c =	16.0 mm
d =	12.0 mm

* CUT FOIL TO DIM. "b"

7	WASHERS	SK5	NICKEL
6	OUTER BODY	BRASS	BL. NICKEL
5	GASKET	SILICONE	N/A
4	CRIMP SLEEVE	BRASS	NICKEL
3	INSULATOR	PTFE	N/A
2	CENTRE CONTACT	BRASS	GOLD
1	BODY	BRASS	NICKEL
ITEM	DESCRIPTION	MATERIAL	PLATING

A4	SHEET 1 OF 1		DIMENSIONS ARE IN MILLIMETERS		
REVISION :	A05		NAME	SIGNATURE	DATE
DRAWN		GE		19/03/2008	
ISSUE :	2	CHK'D	IG	19/03/2008	
		APPV'D			
6-8 COLNE ROAD, TWICKENHAM, MIDDLESEX. TW1 4JR					
THE INFORMATION IS GIVEN AS AN INDICATION ONLY AND IS SUBJECT TO CHANGE WITHOUT NOTICE. IN THE CONTINUAL GOAL TO IMPROVE OUR PRODUCTS, WE RESERVE THE RIGHT TO MAKE ANY MODIFICATIONS NECESSARY WITHOUT PRIOR NOTICE.					