

BNC STRAIGHT CRIMP/CRIMP PLUG 10-005-D126-FB

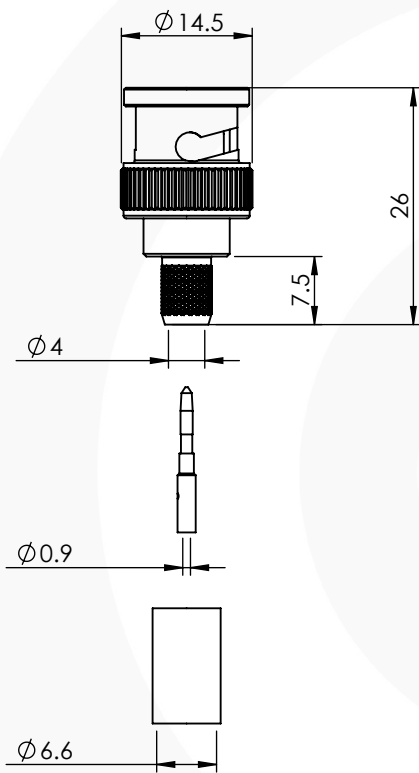

images for illustration purposes only



Suitable for Cables:

(FB) Belden 1505A, Draka 0.8/3.7 A/F, Image 720

Stripping Dimensions

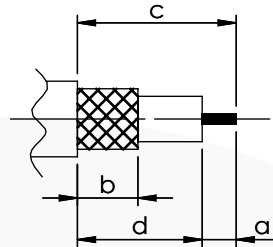

- a = 4.0 mm
- b = 8.0 mm
- c = 16.0 mm
- d = 12.0 mm

* CUT FOIL TO DIM. "b"

Assembly Procedure: AP001

Tooling

Centre Contact: Hex 1.72mm A/F Tool No: 96-HTS-76

Crimp Sleeve: HEX 6.48mm A/F Tool No: 96-HTS-76

Alignment Tool: Not Applicable Extraction: 96-2208

Environmental Specification

Operating Temp: -55 to +155 Deg C.

IP Rating (Mated): IP 64

Electrical Specification

Impedance: 75 Ohm

Frequency: 0-18 GHz

Dielectric W/V: 1500 Veff

Insulation res: 5000 M-Ohm

Surpasses ST2081-1 & ST2082-1 for 6G-SDI & 12G-SDI

Mechanical Specification

Contact Retention: 10 N min

Cable Retention: 200 N min

Mating cycles: 500

Weight: 9.85 g

Connector Interface

image for illustration purposes only

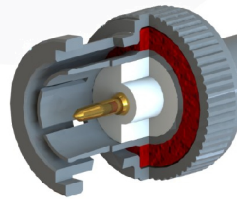

2/9/2017 8:34:04 AM
311.627062101091.W

Trc1 S11 dB Mag 10 dB/ Ref 0 dB Cal Gat

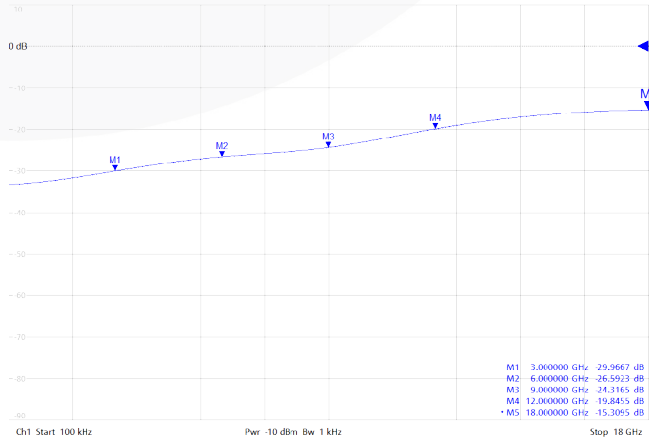

7	WASHERS	SK5	NICKEL
6	COUPLING NUT	ZINC	NICKEL
5	GASKET	SILICONE	N/A
4	CRIMP SLEEVE	BRASS	NICKEL
3	INSULATOR	PTFE	N/A
2	CENTRE CONTACT	BRASS	GOLD
1	BODY	BRASS	GOLD
ITEM	DESCRIPTION	MATERIAL	PLATING

A4	SHEET 1 OF 1	DIMENSIONS ARE IN MILLIMETRES		
REVISION :	B01	NAME	SIGNATURE	DATE
ISSUE :	5	DRAWN	IG	14-Nov-13
		CHK'D	GE	15-Nov-13
		APP'V'D		
6-8 COLNE ROAD, TWICKENHAM, MIDDLESEX. TW1 4JR				
THE INFORMATION IS GIVEN AS AN INDICATION ONLY AND IS SUBJECT TO CHANGE WITHOUT NOTICE. IN THE CONTINUAL GOAL TO IMPROVE OUR PRODUCTS, WE RESERVE THE RIGHT TO MAKE ANY MODIFICATIONS NECESSARY WITHOUT PRIOR NOTICE.				