

## BNC STRAIGHT CRIMP / CRIMP PLUG

### 10-005-B36-FK

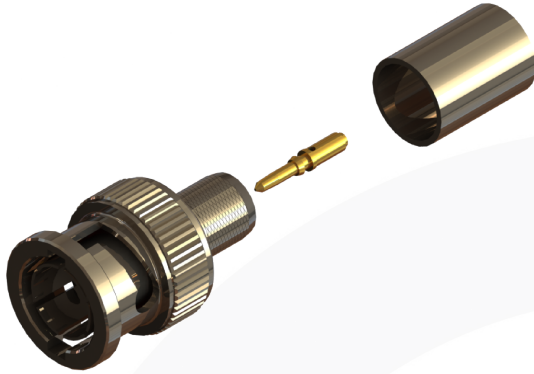

images for illustration purposes only

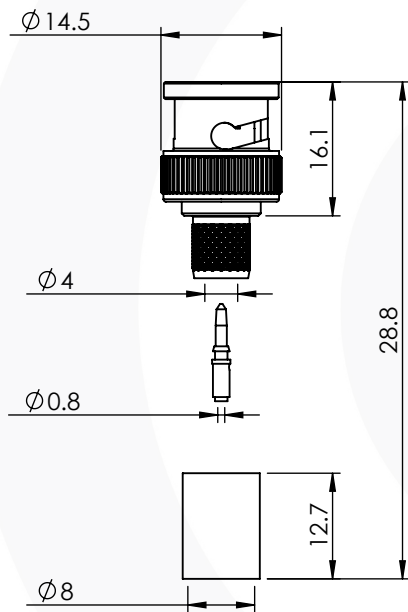

### Suitable for Cables:

(FK) TACHII TCX-4CFWS

### Stripping Dimensions

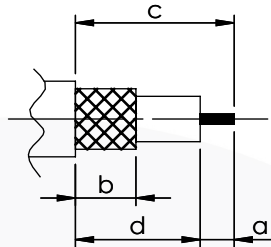

a = 4.0 mm  
b = 8.0 mm  
c = 16.0 mm  
d = 12.0 mm

\* CUT FOIL TO DIM. "b"

### Assembly Procedure: AP001

### Tooling

Centre Contact: HEX 1.72 A/F Tool No: 96-HTS-75A

Crimp Sleeve: Hex 8.23mm A/F Tool No: 96-HTS-75A

Alignment Tool: Not Applicable Extraction: 96-2208

### Environmental Specification

Operating Temp: -55 to +155 Deg C.

IP Rating (Mated): IP 64

### Electrical Specification

Impedance: 75 Ohm

Frequency: 0 - 4.5 GHz

Dielectric W/V: 1500 Veff

Insulation res: 5000 M-Ohm

### Mechanical Specification

Contact Retention: 10 N min

Cable Retention: 200 N min

Mating cycles: 500

Weight: 10.83 g

### Connector Interface

image for illustration purposes only

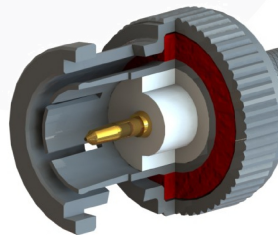

| 7    | WASHERS        | SK5      | NICKEL  |
|------|----------------|----------|---------|
| 6    | BAYONET CAP    | ZINC     | NICKEL  |
| 5    | GASKET         | SILICONE | N/A     |
| 4    | CRIMP SLEEVE   | BRASS    | NICKEL  |
| 3    | INSULATOR      | PTFE     | N/A     |
| 2    | CENTRE CONTACT | BRASS    | GOLD    |
| 1    | BODY           | BRASS    | NICKEL  |
| ITEM | DESCRIPTION    | MATERIAL | PLATING |

|  |              |                               |        |           |          |
|--|--------------|-------------------------------|--------|-----------|----------|
| <b>A4</b>  | SHEET 1 OF 1 | DIMENSIONS ARE IN MILLIMETRES |        |           |          |
| REVISION :   | A00          |                               | NAME   | SIGNATURE | DATE     |
| DRAWN  | 1            |                               | P.P.   |           | 02/10/19 |
| ISSUE :  | 1            |                               | CHK'D  | G.E.      | 03/10/19 |
|  |              |                               | APPV'D |           |          |
| <p>6-8 COLNE ROAD,<br/>TWICKENHAM,<br/>MIDDLESEX.<br/>TW1 4JR</p> <p>THE INFORMATION IS GIVEN AS AN INDICATION ONLY AND IS SUBJECT TO CHANGE WITHOUT NOTICE. IN THE CONTINUAL GOAL TO IMPROVE OUR PRODUCTS, WE RESERVE THE RIGHT TO MAKE ANY MODIFICATIONS NECESSARY WITHOUT PRIOR NOTICE.</p> |              |                               |        |           |          |