

BNC STRIAGHT CRIMP/CRIMP PLUG 10-005-B36-AI

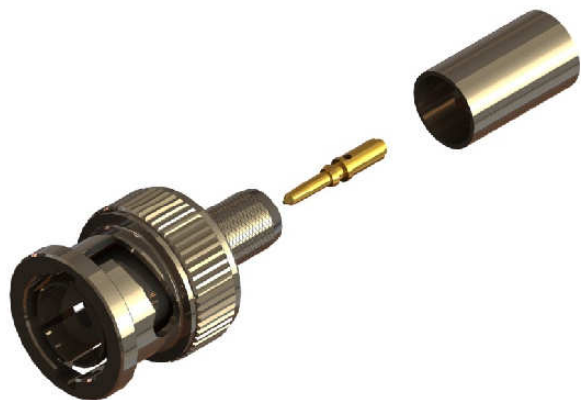

images for illustration purposes only

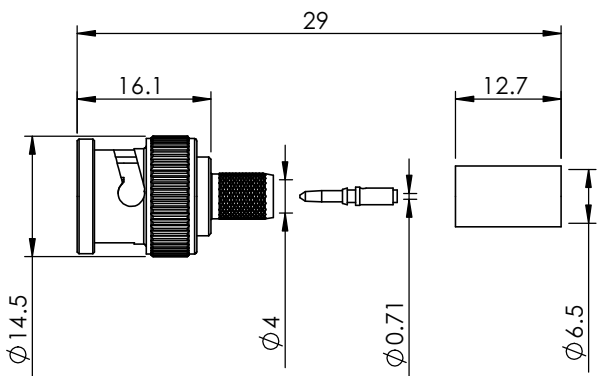

Suitable for Cables:

(AI) RG59, URM104, URM70, RG62, KX6, KX52, KX30

Stripping Dimensions

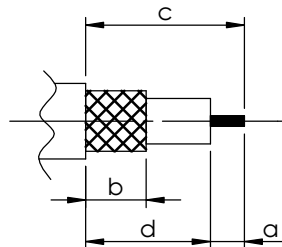

a = 4.0 mm
 b = 8.0 mm
 c = 16.0 mm
 d = 12.0 mm

Assembly Procedure: AP001

Tooling

Centre Contact: HEX 1.72 A/F Tool No: 336A

Crimp Sleeve: HEX 6.48 A/F Tool No: 336A

Environmental Specification

Operating Temp: -55 to +155 Deg C.

IP Rating (Mated): IP 64

Electrical Specification

Impedance: 75 Ohm

Frequency: 0 - 3 GHz

Dielectric W/V: 1500 Veff

Insulation res: 5000 M-Ohm

Mechanical Specification

Contact Retention: 10 N min

Cable Retention: 220 N min

Mating cycles: 500

Weight: 10.09 g

Connector Interface

image for illustration purposes only

Performance

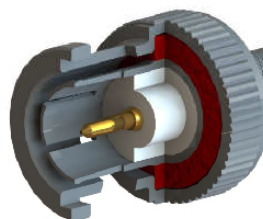

-34.527 dB@ 1.0 GHz
 -25.405 dB@ 2.0 GHz
 -20.839 dB@ 3.0 GHz
 -16.363 dB@ 4.5 GHz

Return Loss Graph

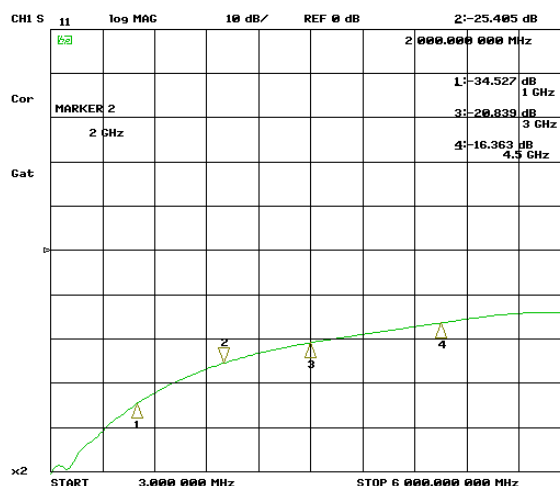

ITEM	DESCRIPTION	MATERIAL	PLATING
7	WASHERS	SK5	NICKEL
6	BAYONET CAP	ZINC	NICKEL
5	GASKET	SILICONE	N/A
4	CRIMP SLEEVE	BRASS	NICKEL
3	INSULATOR	PTFE	N/A
2	CENTRE CONTACT	BRASS	GOLD
1	BODY	BRASS	NICKEL

A4 SHEET 1 OF 1		DIMENSIONS ARE IN MILLIMETRES		
REVISION :	B01	NAME	SIGNATURE	DATE
ISSUE :	2	DRAWN	GE	11/04/2011
		CHK'D	IG	11/04/2011
		APPV'D		
THE INFORMATION IS GIVEN AS AN INDICATION ONLY AND IS SUBJECT TO CHANGE WITHOUT NOTICE. IN THE CONTINUAL GOAL TO IMPROVE OUR PRODUCTS, WE RESERVE THE RIGHT TO MAKE ANY MODIFICATIONS NECESSARY WITHOUT PRIOR NOTICE.				

6-8 COLNE ROAD,
 TWICKENHAM,
 MIDDLESEX.
 TW1 4JR



RoHS
 00002/00/02