

### Assembly Procedure

WEBSITE VIDEO No.

1. Slide crimp sleeve onto cable
2. Strip cable
3. Slide centre contact onto cable conductor up to cable dielectric
4. Ensure that the conductor is visible through the Contact inspection hole.
5. Crimp the centre contact using appropriate sized crimping tool
6. Fan the braid out
7. Slide the cable into the connector and push home until the centre contact "CLICKS" into place
8. Slide the crimp sleeve over the braid
9. Crimp the crimp sleeve using the appropriate sized crimp tool (trim excess braid if necessary)



### Electrical Specification

Impedance: 75 Ohm  
 Frequency: 0 - 1.5 Ghz  
 Dielectric W/V: TBC  
 Insulation res: TBC

### Mechanical Specification

Centre contact retention  
 Axial Force: 10N min  
 Cable Retention: 200N min  
 Mating cycles: 500

### Environmental Specification

Operating Temp: -35 to +70 Deg C

### Tooling

Centre Contact: HEX 1.72mm A/F  
 COAX Tool No: 336A  
 Crimp Sleeve: HEX 8.50mm A/F  
 COAX Tool No: 106X



DO NOT SCALE DRAWING



### DATA SHEET

SHEET 1 OF 1

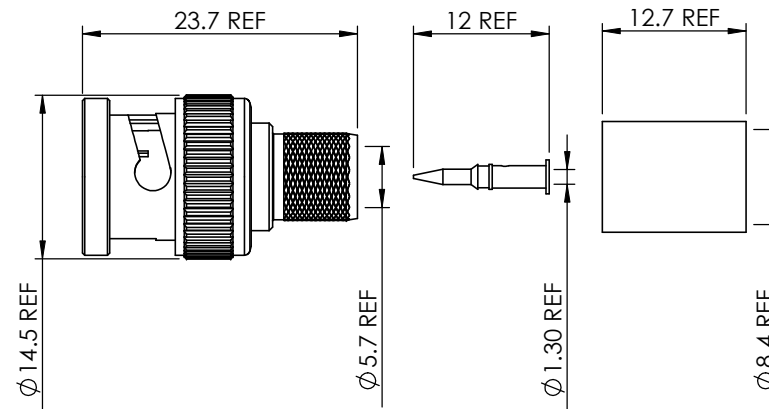

### STRIPPING DIMENSIONS

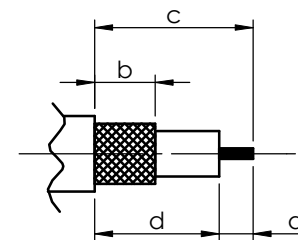

a = 4.0 mm  
 b = 8.0 mm  
 c = 16.0 mm  
 d = 12.0 mm

9	CRIMP SLEEVE	BRASS	NICKEL
8	CENTRE CONTACT	BRASS	GOLD
7	BODY	BRASS	NICKEL
6	WASHER	Fe	NICKEL
5	SPRING	SK5	NICKEL
4	RETAINING RING	SK5	NICKEL
3	GASKET	SILICONE RUBBER	N/A
2	INSULATOR	DELIRIN	N/A
1	COUPLING NUT	DIECAST ZINC	NICKEL
ITEM	DESCRIPTION	MATERIAL	PLATING



**COAX CONNECTORS LTD**  
 6-8 COLNE ROAD, TWICKENHAM,  
 MIDDLESEX. TW1 4JR

**Description** BNC PLUG CT125

**Part Number** 10-005-A0-CC

REVISION : DA00

A4

DIMENSIONS ARE IN MILLIMETERS

NAME	SIGNATURE	DATE
DRAWN	GE	31/03/2010
CHK'D	IG	31/03/2010
APPV'D		

THE INFORMATION IS GIVEN AS AN INDICATION ONLY AND IS SUBJECT TO CHANGE WITHOUT NOTICE. IN THE CONTINUAL GOAL TO IMPROVE OUR PRODUCTS, WE RESERVE THE RIGHT TO MAKE ANY MODIFICATIONS NECESSARY WITHOUT PRIOR NOTICE.